

ACADEMY *of* ART UNIVERSITY®

FOUNDED IN SAN FRANCISCO 1929 BY ARTISTS FOR ARTISTS



School of Architecture



ACADEMY *of* ART
UNIVERSITY®

FOUNDED IN SAN FRANCISCO 1929
BY ARTISTS FOR ARTISTS

Academy of Art University
79 New Montgomery St.
San Francisco, CA 94105

Contact us for more information
E. Info@academyart.edu | T. 1.800.544.2787

Academy of Art University School of Architecture
601 Brannan Street
San Francisco, CA 94107

www.academyart.edu/academics/architecture
www.aaschoolofarchitecture.com
www.architectureschooldaily.com

Visit www.academyart.edu to learn more about total costs, median student loan debt, potential occupations and other information. Accredited Member WASC, NASAD, CIDA (BFA-IAD, MFA-IAD), NAAAB (B.ARCH**, M.ARCH), CTC (California Teacher Credential). *Acting degree program is currently not offering online courses. **B.ARCH is currently in candidacy status.



Contents

Who We Are	3
Curriculum	4
Degree Options	4
San Francisco	6
Graduate Student Work.....	10
Undergraduate Student Work.....	20
Social Engagement.....	32
NAAB Accreditation.....	34
Studio Culture	35
Faculty	36
Faculty Work	42
Facilities	52
Special Programs.....	54
Study Abroad Option 1	56
Study Abroad Option 2.....	60
Public Events	62
Galleries and Exhibitions	64
Alumni	66
Online.....	70
Career Options.....	72
Architectural Licensing in the US ..	73
Academy Life	74
Visit Us.....	76
How to Apply	77

PURSUE A CAREER AS:

ARCHITECTURAL DESIGNER
PROJECT ARCHITECT
PROJECT MANAGER
DESIGN PRINCIPAL
PARTNER IN A FIRM

OUR PROFILE:

- Our urban campus takes advantage of our location in San Francisco's innovation hub.
- Our programs pair conceptual design rigor with technical excellence.
- We embrace and address contemporary culture and societal developments.
- We actively participate in an international up-to-date architectural discourse.
- Our fabrication labs and shop facilities are outstanding.
- We are at the pulse of contemporary research, production, and building design.
- We create a supportive environment recognizing the diversity of our student body.
- Our students have the opportunity to engage in real world community projects.
- Our School of Architecture offers two Study Abroad Programs in Europe.
- Our B.Lab initiative offers design-build studio opportunities.
- Our faculty and students represent a highly diverse and international community.
- We collaborate within a large art university engaging with other creative experts.
- Our Graduates enter the profession well prepared as responsible leaders in their field.
- We offer the only fully Online NAAB Accredited M.Arch and B.Arch Programs in the US.
- We are the only higher arts education institution in the U.S. to have an NCAA athletics program.

We Educate Architects

The School of Architecture is a progressive design laboratory of highly passionate students and a distinguished faculty of practicing architects, who work together to explore the boundaries of one of the most compelling professions you can enter today.

We are dedicated to advancing the field of architecture by offering academic programs that foster critical thinking, artistic vision, and responsible leadership. We offer an excellent design education by developing each student's capacity to synthesize critical thought, architectural vision and technical comprehension.

Dedicated to the relationship between theory, up to date technical developments, advanced architectural design, and the practice of making and building, the program has an exceptional profile. With a distinguished faculty of practicing architects, diverse collaboration teams, emerging technologies, fabrication labs, and sensitivity to sustainable methods – together we will participate in shaping our physical world.

Our international and exceptionally diverse community enables us to propagate a unique culture from which we address relevant questions on the future of our global built environment.

Our Curriculum

Through our programs, we enable our students to become responsible leaders in their field, who have the skills to envision, design and construct a desirable and viable future.

Architecture graduates are critical thinkers and problem solvers that develop a diverse range of skills and qualities during their studies. Supported by the insight of practicing faculty, we strive to educate future architects that are able to bridge artistic vision with technical comprehension.

ARCHITECTURAL EXPLORATIONS



First year studios teach fundamental design skills from which students can pursue their architectural interests. Projects are geared to improve the students' ability to conceptualize, develop, and communicate spatial ideas.

CONCEPTUAL DESIGN THINKING



Through an analysis and understanding of type, program, and site, students will explore the synthesis of an architectural concept from its early design schematics towards its final physical manifestation. We foster critical design thinking skills and teach up to date, effective, and contemporary design processes so our students are capable to be confident and successful once they enter the profession.

TECTONIC UNDERSTANDING



Students develop a high level of competence in the technical aspects of architectural design through thoughtful integration of structure, building, and envelope systems, as well as sustainability and future technologies.

INDEPENDENT INVESTIGATIONS



In their final project students formulate a research topic, and investigate concept, context and typology such as physical site characteristics, environmental and programmatic factors as well as cultural and societal developments that influence their architectural design.

Undergraduate Degrees

Bachelor of Architecture (B.Arch)

Unit requirements

Core	36 units
Major	69 units
Humanities	12 units
Liberal Arts	45 units
TOTAL	162 units

Offered as a first professional degree, the Bachelor of Architecture program provides an intense design education by developing each student's capacity to analyze, synthesize, and develop intelligent architectural designs. The B.Arch allows an undergraduate student to most efficiently pursue an architecture license and successfully enter the profession with a comprehensive portfolio.

Bachelor of Arts in Architectural Design (BA)

Unit requirements

Core	36 units
Major	45 units
Humanities	6 units
Liberal Arts	45 units
TOTAL	132 units

The Bachelor of Arts in Architectural Design is grounded in environmental design, providing a relevant and engaging studio-based and portfolio-driven undergraduate education. Students will develop their abilities and understanding in architectural design, art, architectural history and theory, fundamentals of sustainability and building tectonics, as well as advanced design representation tools.

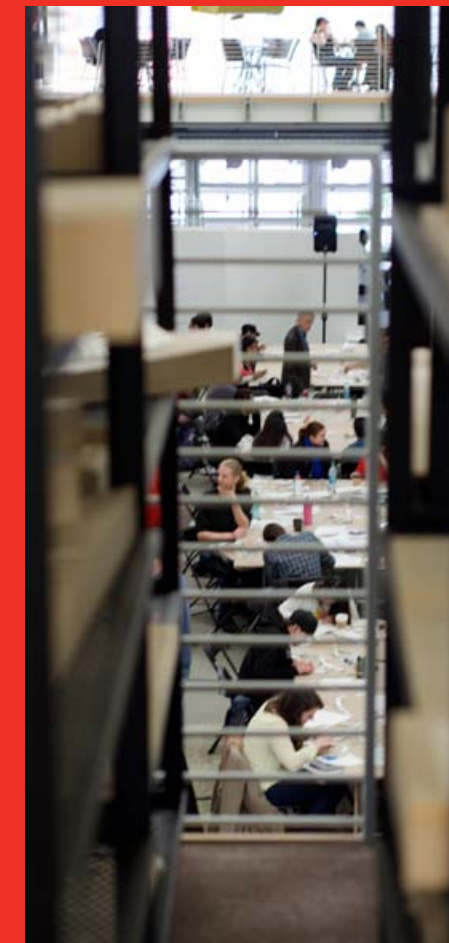

Graduate Degrees

Master of Architecture (M.Arch)

Unit requirements Track I

Major	48 units
Electives	9 units
Directed Study	6 units
TOTAL	63 units

Unit requirements Track II

Major	66 units
Electives	15 units
Directed Study	6 units
TOTAL	87 units

The NAAB accredited Master of Architecture (M.Arch) is a holistic professional program offered in two tracks. Dedicated to the relationship of theory, up to date technical developments, contemporary architectural design and the practice of making and building. The program bridges the latest design methods in architecture with integrated technical competence. The professional M.Arch degree offers an internationally recognized credential and is the first step towards professional licensure in the US as well as in many other countries around the globe.

Master of Art of Advanced Architectural Design (MA.ARH)

Unit requirements Track I

Major	24 units
Major Elective	6 units
Elective	6 units
TOTAL	36 units

Unit requirements Track II

Major	42 units
Major Elective	6 units
Elective	12 units
TOTAL	60 units

The WSCUC accredited Master of Arts in Advanced Architectural Design (MA-ARH I and MA-ARH II) post professional degree programs allow students to specialize in a particular area of interest. Dedicated to advanced architectural design investigations immersed inside a large and vibrant art and design university, the program has an exceptional profile. Students develop their own design interests covering diverse fields that mediate between contemporary architectural developments, advanced design theory and techniques, and emerging technology.

San Francisco

Our home since 1929. We are located in the heart of the San Francisco Bay Area, a global hub for forward thinking ideas.

Cultural tolerance, open mindedness, and ethnic diversity, continue to define this city. The international arts and cultural scene and the leading technical innovation that originates here is changing and shaping our world like no other region.

We are utilizing this exceptional location and our urban campus as a laboratory for our architectural explorations that project far into the future of what architecture has to offer, what it can be, or might become.

In addition to this, the Bay Area has an array of exceptional architecture from recognized masters like Frank Lloyd Wright, Richard Neutra, and Pier-Luigi Nervi to international contemporary practices like Snøhetta, Foster and Partners, and Herzog de Meuron among many others. In addition to this, many new and exciting buildings are currently projected by world renown firms like OMA, Jeanne Gang, Heatherwick Studio, Bjarke Ingels Group, and many others.

San Francisco is truly among one of the most exciting places in the world to study architecture.



ACADEMY OF SCIENCE RENZO PIANO

World renowned architect Renzo Piano's vision for the new California Academy of Sciences creates an outstanding model for sustainable design at an unprecedented scale, the building is among the largest museums of natural history in the world with roughly about 1.5 million visitors annually.

DE YOUNG MUSEUM HERZOG DE MEURON

Designed by the internationally renowned Swiss firm of Herzog & de Meuron, winners of the 2001 Pritzker Prize, the de Young Museum in San Francisco's Golden Gate Park is among the best new museum buildings in the world. The elegant, twisting tower rising above the tree line, provides visitors with dramatic views.



V. C. MORRIS GIFT SHOP FRANK LLOYD WRIGHT

The V. C. Morris Gift Shop is located at 140 Maiden Lane in downtown San Francisco. It was designed by Frank Lloyd Wright in 1948 as a proof of concept and physical prototype for the circulation ramp at the seminal Solomon R. Guggenheim Museum. In 2007 the store was listed among the 150 favorite buildings in America by the American Institute of Architects.

These are just three examples of the world-class architecture San Francisco and the Bay Area has to offer. See a selected list on the right for more and come here to experience it for yourself.

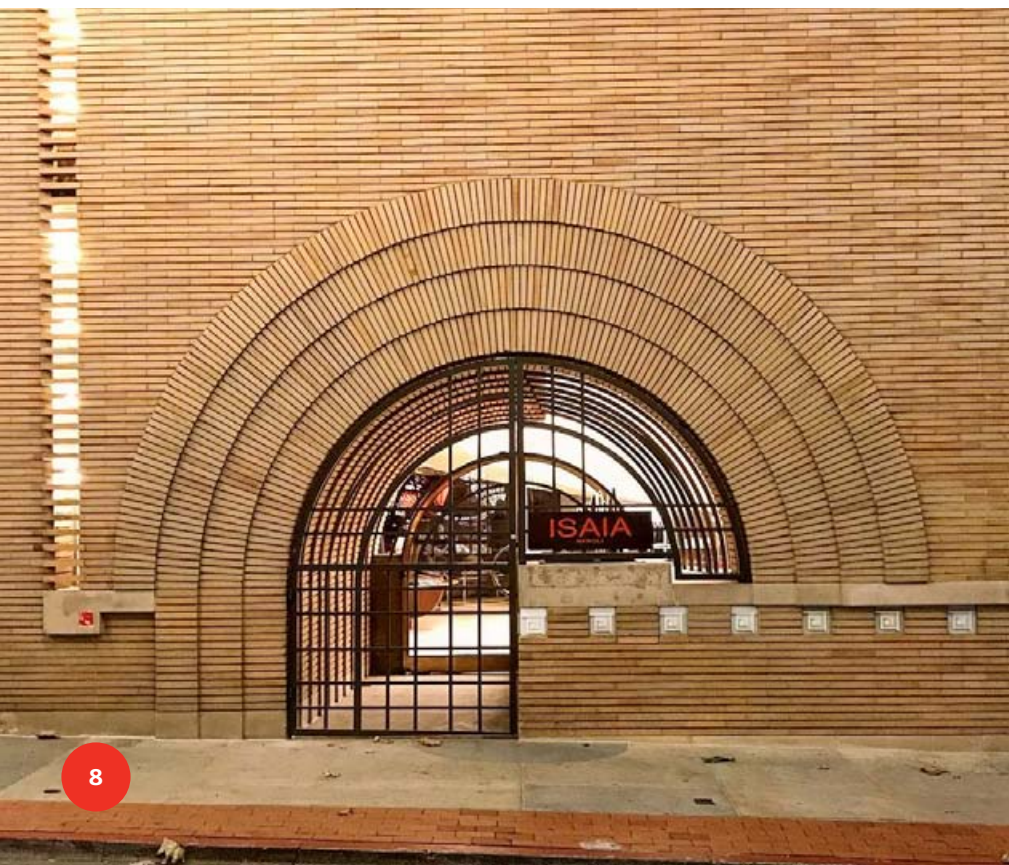

THEATRES & VENUES

The Fillmore / Bill Graham Civic Auditorium / The Warfield / The Shoreline Amphitheater / Great American Music Hall / The Fox Theatre / SHN Orpheum Theater / The American Conservatory Theater / The Castro Theatre / SFJAZZ / SF Conservatory of Music / San Francisco Opera / SF Symphony / SF Ballet

PARKS AND URBAN SPACES

Golden Gate Park / Embarcadero / Union Square / Yerba Buena Gardens / Levi Plaza / Presidio of San Francisco / Crissy Field / Marina Green / South Park / Ocean Beach / Land's End / Marin Headlands

PUBLIC TRANSPORTATION

MUNI / AC Transit / BART (Bay Area Rapid Transit) / Cal Train / Golden Gate Transit / SamTrans / Plan Your Trip with 511.org

MUSEUMS

Asian Art Museum / Contemporary Jewish Museum / de Young Museum / California Academy of Sciences / Legion of Honor / Yerba Buena Center for the Arts / The Beat Museum / The Berkeley Museum / Cable Car Museum / Palace of Fine Arts Theatre / Exploratorium / Walt Disney Family Museum / Museum of Performance & Design / Museum of Craft & Design / Museum of the African Diaspora / Museo Italo Americano / Oakland Museum of California / Museum of Modern Art (MOMA) / Cartoon Art Museum / Academy of Art University Automobile Museum

AAU GALLERIES

Atelier / 625 Gallery / The Cannery / 688 Gallery / Spring Show

NEWS

SFGate / SF Bay Guardian / The San Francisco Chronicle / The SF Weekly

MAJOR WORKS OF ARCHITECTURE

Marin Civic Center - Frank Lloyd Wright / De Young Museum - Herzog and de Meuron / California Academy of Sciences - Renzo Piano / Transamerica Pyramid - William L. Pereira & Associates / Federal Building - Morphosis / University Art Museum Berkeley - Mario J. Ciampi / SF Art Institute - Paffard Keating Clay / Yerba Buena Lofts - Stanley Saitowitz & Natoma Architects / Music Library at UC Berkeley - Mack Scogin Merrill Elam Architects / Russell House - Erich Mendelson / One Maritime Plaza - SOM / Jewish Contemporary Museum - Daniel Libeskind / Hyatt Regency / John Portman & Associates / Saint Mary's Cathedral - Pier Luigi Nervi / Congregation Beth Shalom - Stanley Saitowitz / Hallidie Building - Willis Polk / SF Jazz - Mark Cavagnero Associates / V.C. Morris Gift Shop - Frank Lloyd Wright / 1234 Howard Street & 1028 Natoma Street - Stanley Saitowitz & Natoma Architects / Crown-Zellerbach Building One Bush Plaza - SOM / Mission Bay Block 27 Parking Structure - WRNS Studio / Golden Gate Bridge - Joseph B. Strauss / The Cathedral of Christ the Light - SOM / Dominus Winery - Herzog and de Meuron /



DISCOUNTS

Our partnerships get our students further with discounts that let them enjoy the San Francisco life to the fullest.

For a list of where our students can get some great deals visit:
www.academyart.edu/students/city-life

Our Graduate Students

Throughout the studio centric program, our graduate students become top designers, who share a deeper understanding of architecture. We provide them with the knowledge and abilities necessary to investigate their ideas and transform their architectural visions into built reality. We strongly believe in our students' potential to shape the future of the our environment as critical leaders in their field.



▲
LUNA YUE DENG
M.ARCH THESIS

This proposal tackles the question of anthropogenic climate change as it relates to the architectural environment of an urban farming center in the northern part of the city of Beijing. The architectural response of the project follows from a close investigation of resilience through climatic adaptation.

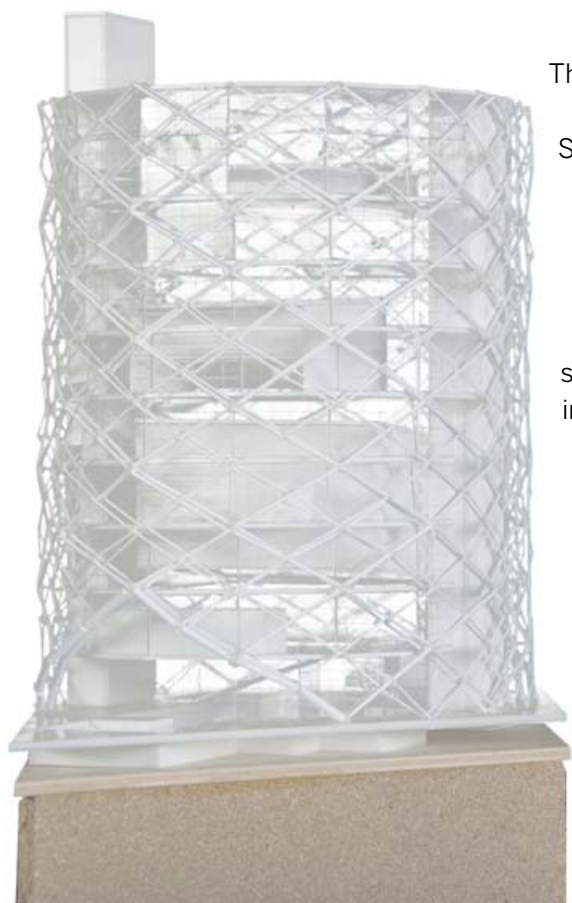

◀ **MEHUL PATEL**
M.ARCH DESIGN
STUDIO

This design for a Hybrid Tower in the vibrant SOMA district employs an intelligent steel structure that utilizes the resulting tectonic freedom in order to extract surprising spatial qualities for the interior of the building.

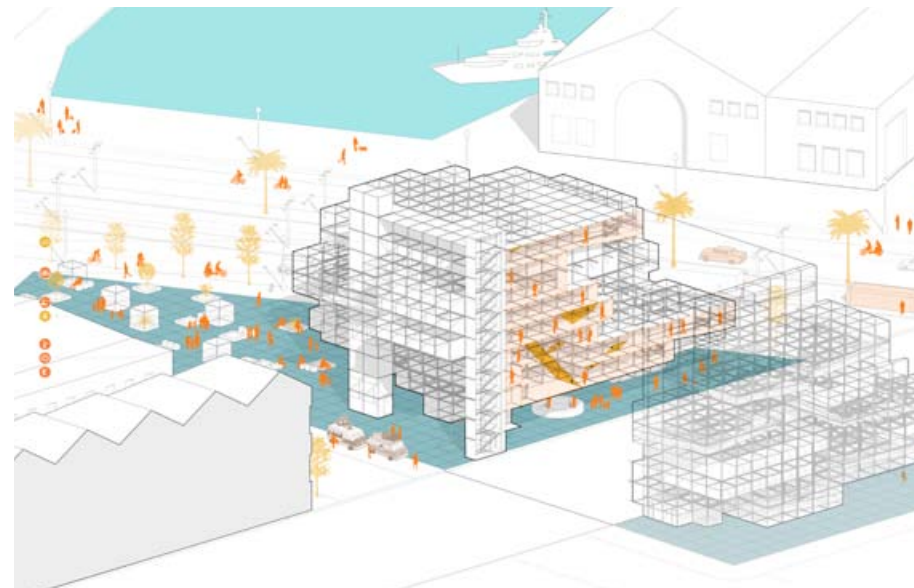

▲
ALIREZA ARABSHAHI
M.ARCH THESIS

The project connects San Francisco to Silicon Valley by creating an aggregation of spatial pixels acting as a virtual technology museum. The concept results in a three-dimensional display or habitable screen. The proposal acts as a device that will allow people to explore past, present, and future technology in an entirely new way.

YUBO SHEN ▶
M.ARCH DESIGN STUDIO

The tectonics of a roof assembly for an underground structure led to multiple abstract models exploring various dome shapes that are closely related to the spatial program and programmatic requirements, as well as the structural properties of the larger architectural design project.



◀ **FANG HUIZHONG**
M.ARCH DESIGN STUDIO

This design for a museum complex in San Francisco's Presidio Park explores conceptual building design in relation to typology, site, and context. With their distorted reflections, the curved glass walls of the public areas create a mysterious atmosphere, which mediates between the art and the natural experiences in the museum design.

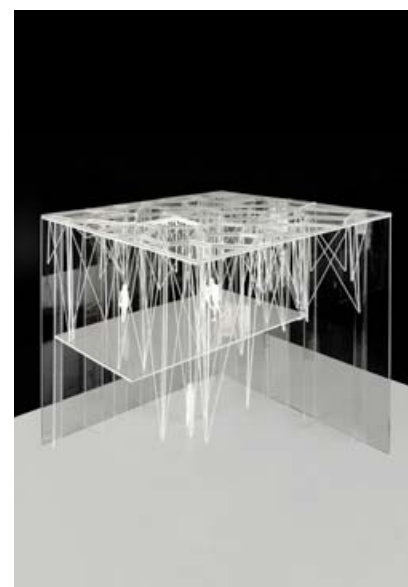

◀ **ZULHUMAR TURGHUN**
M.ARCH DESIGN STUDIO

The design for a new library typology in Lincoln Park, San Francisco, proposes an innovative tensile roof assembly that is based on cloud like information aggregation in this library concept. The tectonic assembly engages in an interesting dialectic relationship with the more conceptual aspects of this particular design approach.

NOJAN ADAMI, M.ARCH ▶
M.ARCH THESIS

Following current political developments on a global scale, this thesis is based on the factual observation of the societal phenomenon of political “numbness” which does not prevail as much in societies that possess and support a more dexterous street culture. The subsequent proposal of the “Political Bazaar” is an underground market and an above-ground open plaza design, which has the ability to serve as an architectural paradigm for activating and further urbanizing American city centers.

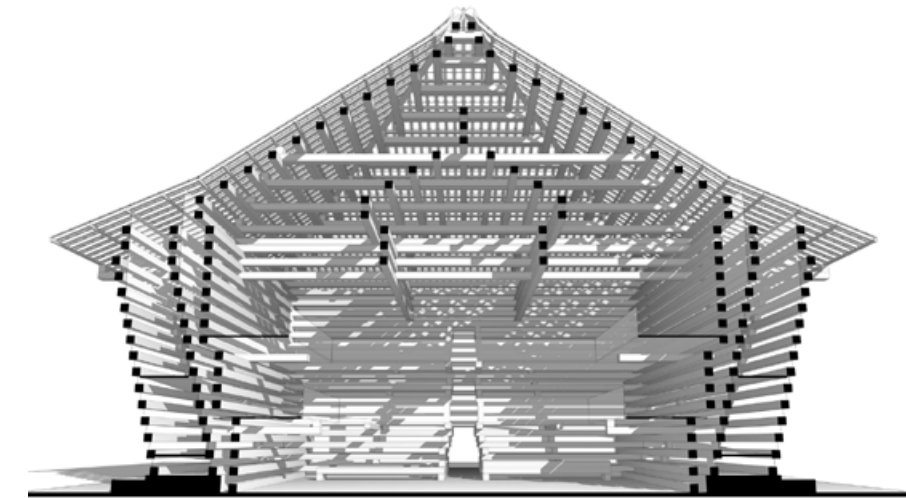

▲ JIALE MA - M.ARCH THESIS

The proposal “Soul Keeper: Center for Intangible Culture” concerns Xi’an, a UNESCO World heritage site, where new construction mimics and replaces historic buildings. The intangible historical culture in cities like Xi’an is often evident through a specific vernacular resulting from cultural traditions that create a certain local identity. The proposed center mediates this craft of intangible cultural practices and stimulates interaction with local inhabitants. The architecture bridges traditional and contemporary building methods to create a realm of authenticity that is deeply rooted in its locality.

YANG HU ▶
M.ARCH INTRODUCTORY DESIGN STUDIO

“Soft Exchange” architectural infiltration of transient populations and their commuter patterns at San Francisco’s Powell Station.

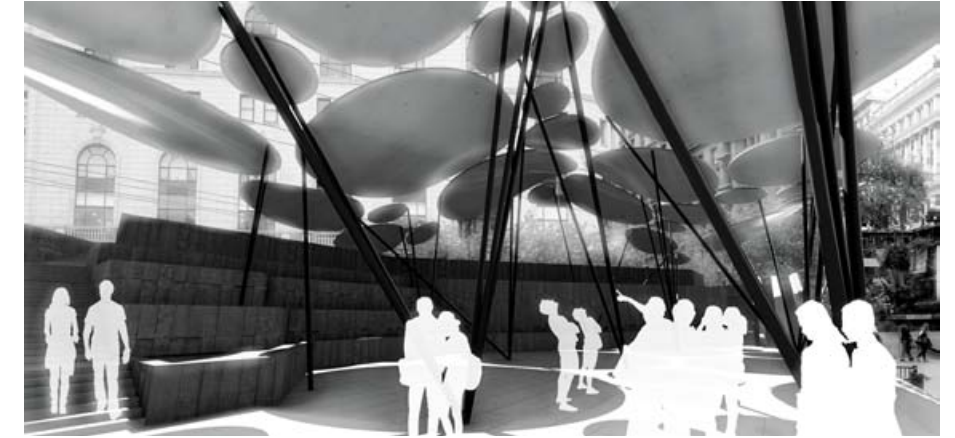

◀ HANNAH MOON
M.ARCH THESIS

The project is a vertical exploration tower within a river in Rovaniemi, Finland. The building harvests energy for itself and the building programs. It accesses and stores power from the nearby river. The building seeks to be an icon, a celebration of immersion into the Lapland region and its natural resources while concurrently embracing technological advancement and sustainability.

TARA ABEDINI ▶
M.ARCH DESIGN STUDIO

The design for an urban natatorium in San Francisco’s SOMA district applies a spatial phenomenology that is pushing the limits of the experiential qualities of bathing and the boundary between public and private through this considerate approach to the typology.



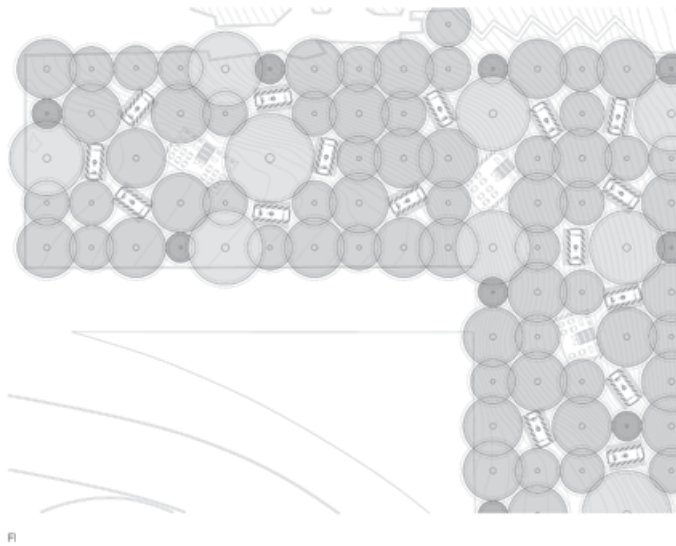
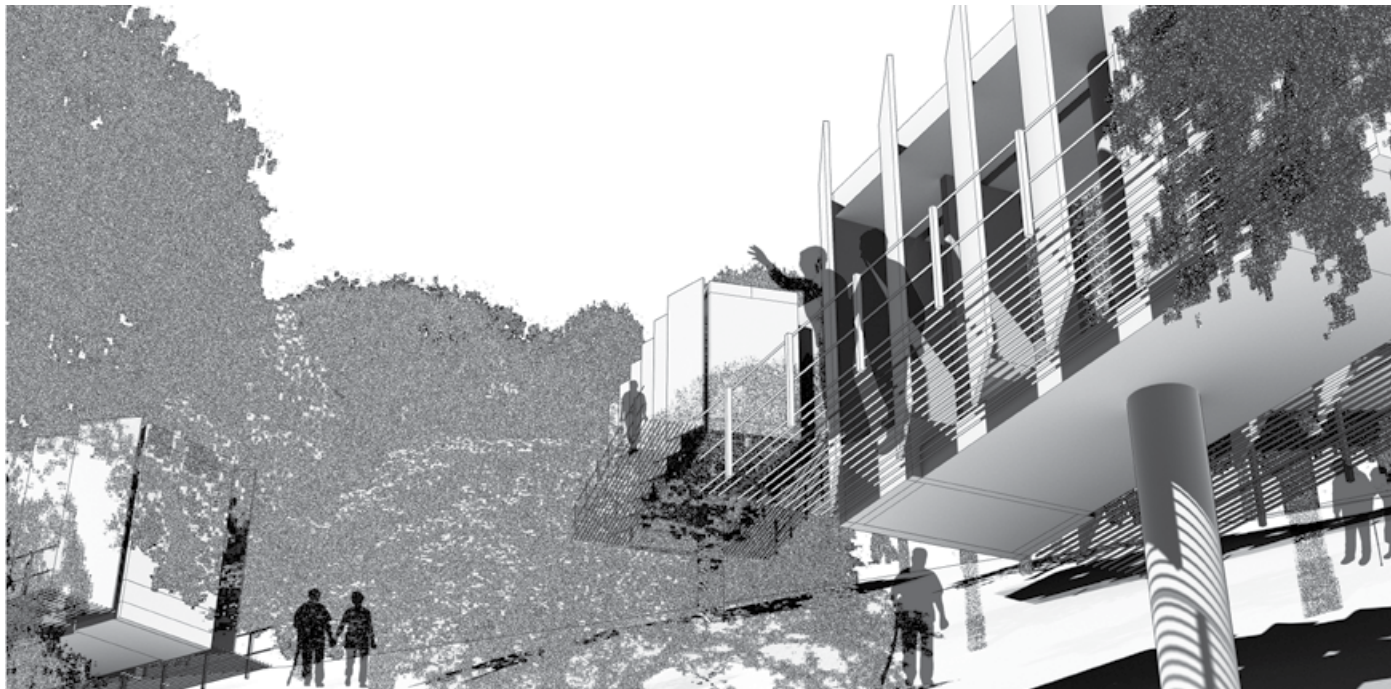

◀ **YING WANG ▲**
M.ARCH STUDIO

The proposal explores human experiences and cultural idiosyncrasies as a programmatic basis to develop a sequence of experiences. A sequence of site mapping analysis drawings were instrumental in the development of a scheme for the projected architecture. The student then implemented her abstract concept into a distinct program that deals with specific architectural phenomena.

BEN XUHAN SHI ▶
M.ARCH THESIS

This thesis project attempts to link architecture and education through the design of a kindergarten that acts as a 3-dimensional text book. By researching children's brain development stages and different types of intelligence, as well as materials, methods of construction and spatial qualities, the goal is to design a new space for learning.



TSZ WAI LEUNG ▶
M.ARCH THESIS

"LiSC" or "Living in Shared Community" is an innovative housing proposal that utilizes the concept of shared economy to address the chronic housing challenges that face cities worldwide. The project introduces a socially, economically and environmentally sustainable community that is founded on the opportunities of sharing across all these sectors in response to the lack of affordable housing in urban areas. The projects generates an affordability for lower and middle-income urban populations, as well as social and cultural amenities through an increase in the communal activities that take place in the public spaces throughout the project. (See this project also on the cover of this book).

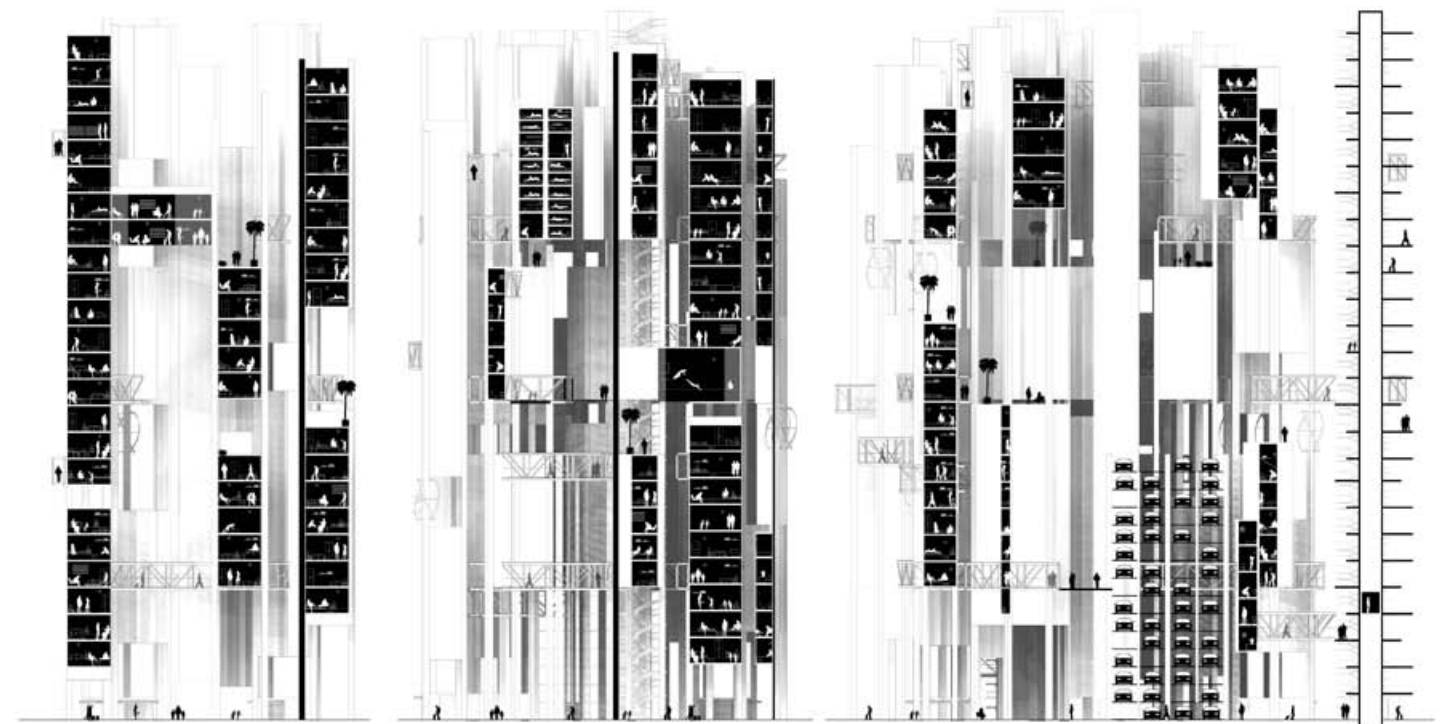

**ALEXANDER SIEGFRIED ▶
M.ARCH DESIGN STUDIO**

The striking design for a new modern art museum in the Presidio Park in San Francisco incorporates an elegant, innovative, as well as smart tectonic approach. The resulting light roof rises out of the natural topography and spans over open spaces creating an engaging dichotomy with the art that is housed under it. The design carefully bridges the relationship of the beautiful landscape with a similar beautiful building.

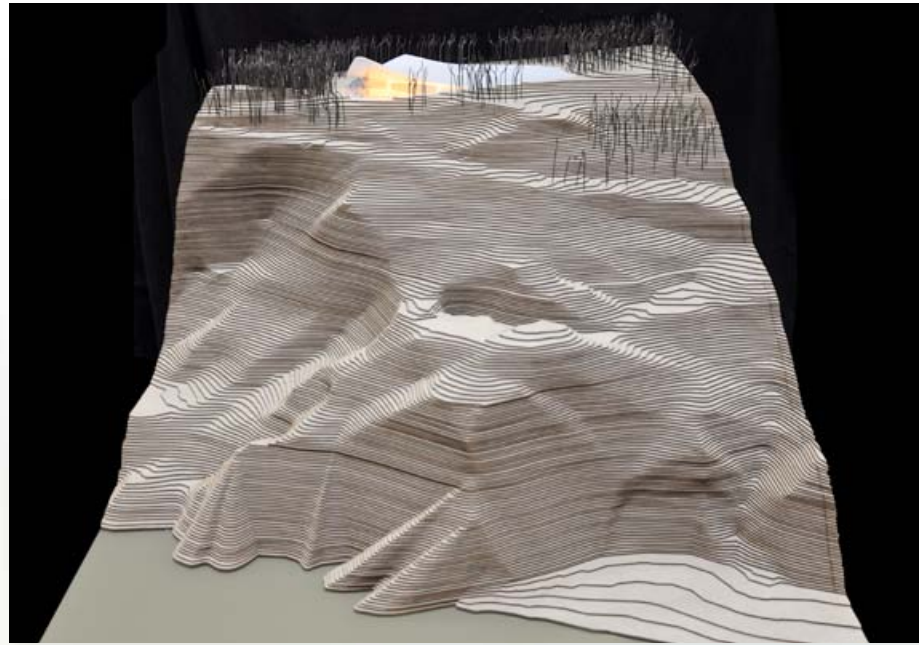

**KAWINTHRA
CHONGSUKSANTIKUL
M.ARCH DESIGN STUDIO**

The design for a public library in downtown San Francisco, reinvents the given typology of library buildings in the digital age and carefully integrates itself into the compelling urban fabric.

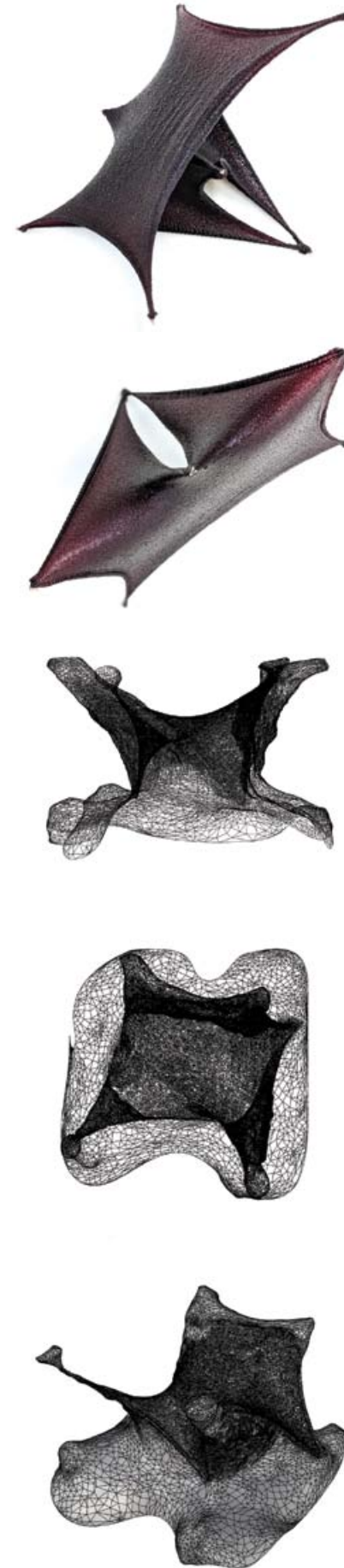

**◀ DIGITAL MORPHOLOGY
RESEARCH BY DESIGN**

The generation of minimal surface structures was investigated through tensile experiments that train an artificial intelligence to predict optimized emerging forms.

**▲ DIGITAL FABRICATION
RESEARCH BY DESIGN**

The group project above and below investigates properties of concrete casts applying a time based oscillating formwork through robotic technology.



**ROBOTIC ASSEMBLY ▶
RESEARCH BY DESIGN**

Wood structure assembly test applying robotic technology in the construction of simple wood structures and joinery systems.

Our research by design is geared to the latest developments in building construction, in order to prepare our students to an ever changing future.



Our Undergraduate Students

Building on the foundation of fundamental design, ethical awareness, and liberal arts, we offer intermediate and advanced design studios that help the students to unfold their creative potential. Our undergraduate students enter the profession well prepared, as we educate them to become critical thinkers and visionary designers with skills and experiences to carry them into their architectural careers.



KENTA OYEB
B.ARCH 2ND YEAR
DESIGN STUDIO

This studio asks students to balance the design of a homeless shelter that gives dignity to those experiencing homelessness while embracing the community in a meaningful way. Kenta's homeless shelter for musicians uses reflections (therapeutic and acoustic) as the guiding principle.



▲ **MALAK BELLAJDEL, NHAT HUYNH,**
HUSSEIN SALEH
B.ARCH 2ND YEAR DESIGN STUDIO

This experimental design project launched with an investigation of how the mutation of abnormal cells in the body mutate. The result is a proposal for a fashion laboratory where the program takes advantage of the transformations of structure, space and form. Students work at the scale of the body and then the scale of a building in this studio to explore the possibilities offered by the study of non-architectural and natural processes.

ROY PARK & INTUON SAICHUA
B.ARCH 1ST YEAR DESIGN STUDIO

The construction of a Case Study model of a house by San Francisco architect, Ann Fougeron allows students to analyze the strong design logic utilized in the realization of a built project.

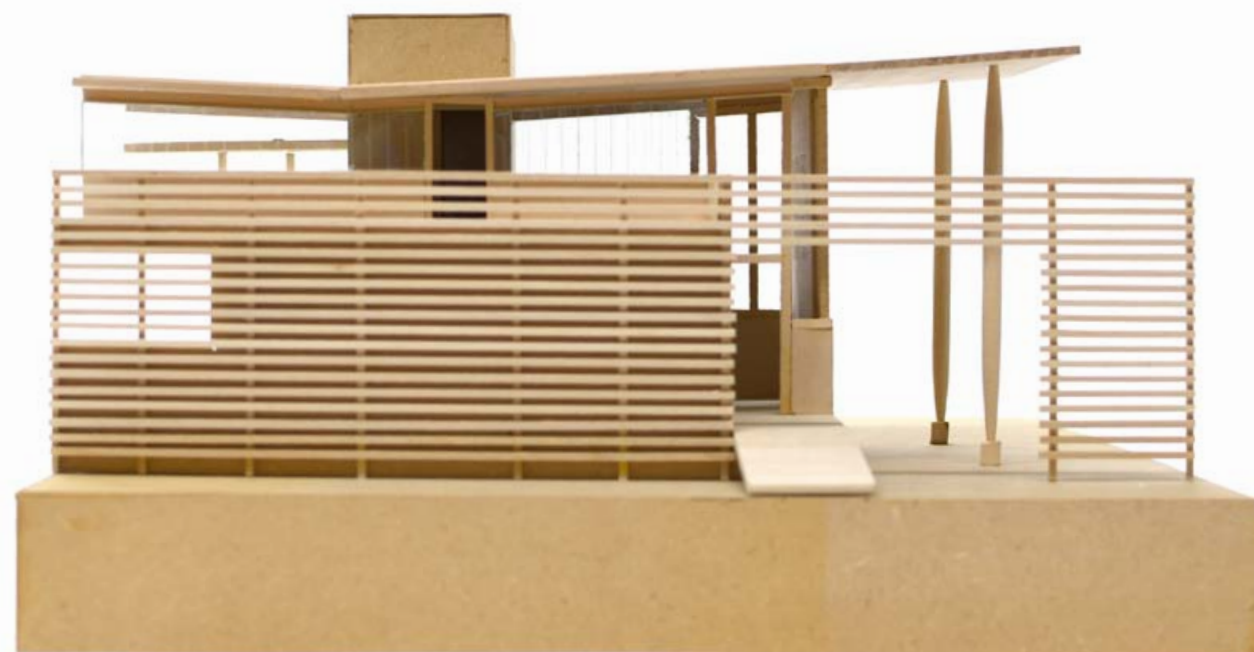

OSCAR LOPEZ ▶
B.ARCH SECOND YEAR
MEDIA CLASS

A series of architectural drawings were collaged to produce a novel interpretation of the building. This digital media course questions how drawings and models can be descriptive and exploratory.



◀ **MENG FAN**
B.ARCH 1ST YEAR
DESIGN STUDIO

This project is based on a study of a series of spatial transformations that are then combined and further developed to become a "passageway" in which the experience of a path is enhanced by shifting architectural planes creating unique solid and void patterns.

OSCAR FRICK ▶
B.ARCH SECOND YEAR
MEDIA CLASS

This drawing explodes the design for a pavilion to demonstrate how the different pieces interact. By pulling them apart, this reveals the relationship between part and whole.

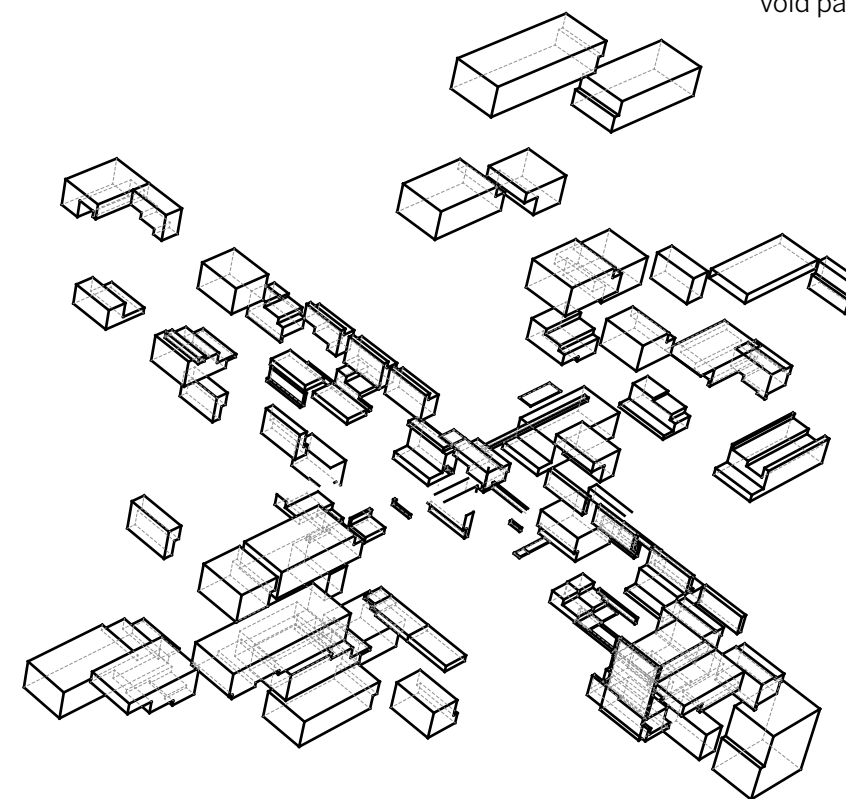

**MAURITS DE GANS B.ARCH ▶
FOURTH YEAR STUDIO**

A series of public urban rooms are vertically organized and connected via circulation axes in a tall building. Intertwined with the public urban rooms are private urban rooms that sometimes overlap where programmatically appropriate to encourage discovery of shared interests that lead to new opportunities for interactions.

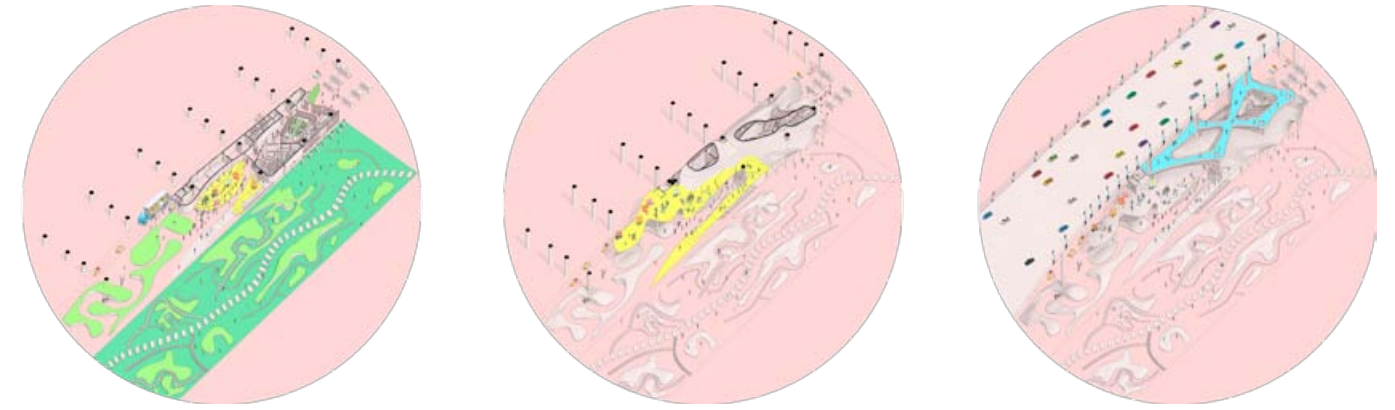
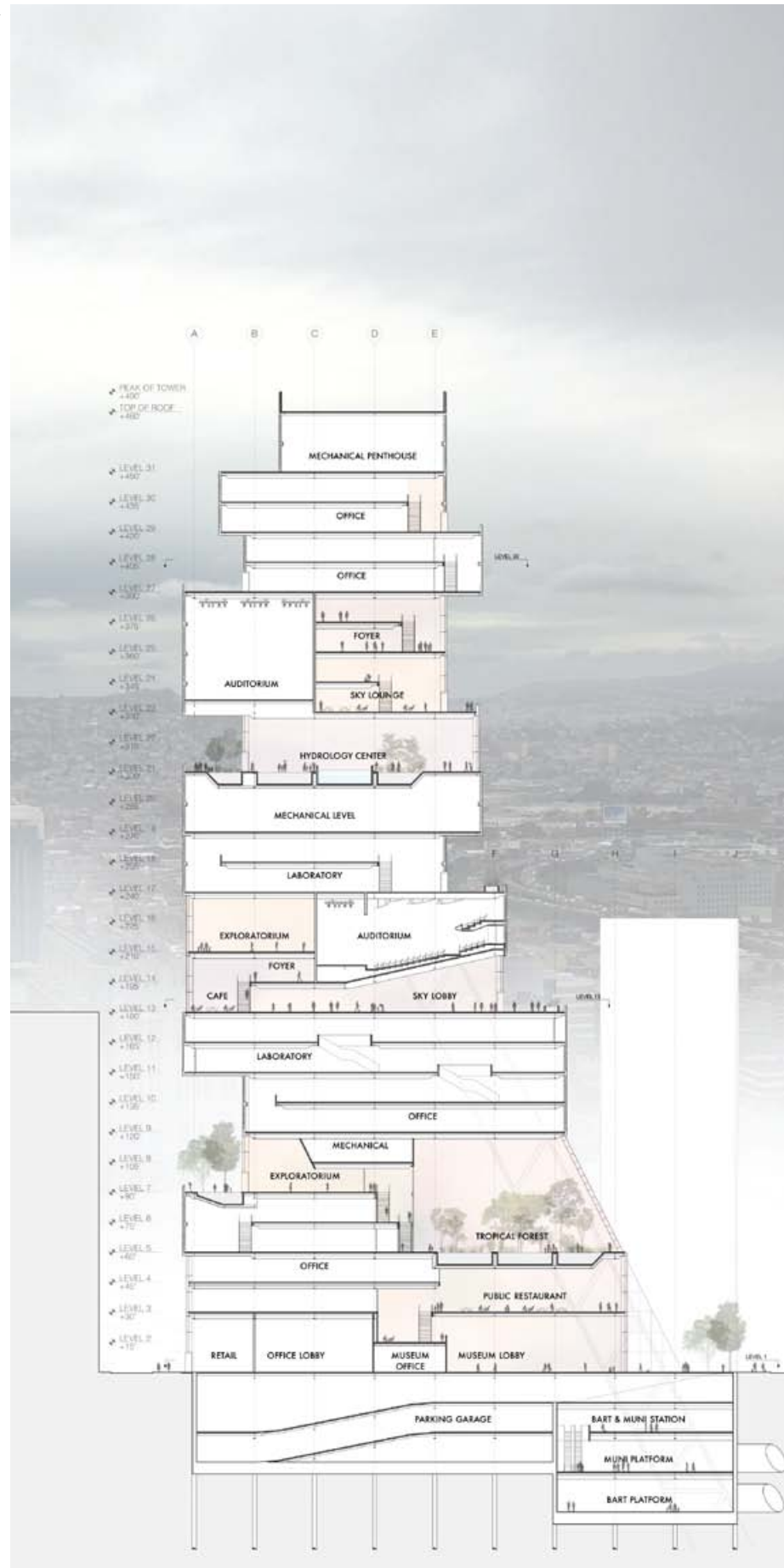

**▲ SAL ALAJMI,
B.ARCH THESIS STUDIO**

As a counterpoint to the industrialization of the American food production, the project integrates urban farms, small-scale food processing facilities, farmers' markets, and a food museum for consumers to reduce the gap between people and food in order to educate upcoming generations for nutritious living.

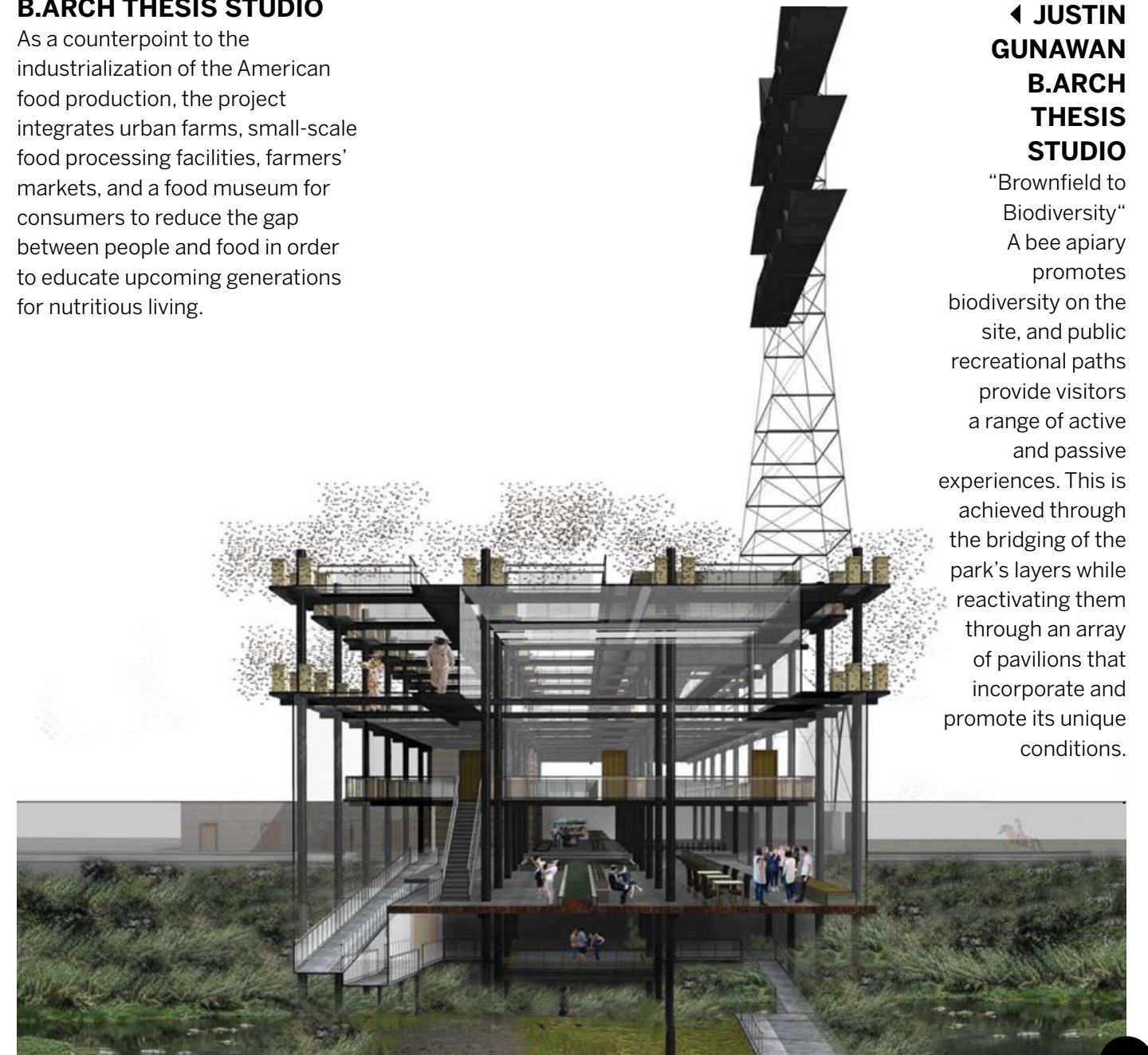

**◀ JUSTIN
GUNAWAN
B.ARCH
THESIS
STUDIO**

"Brownfield to Biodiversity"
A bee apiary promotes biodiversity on the site, and public recreational paths provide visitors a range of active and passive experiences. This is achieved through the bridging of the park's layers while reactivating them through an array of pavilions that incorporate and promote its unique conditions.

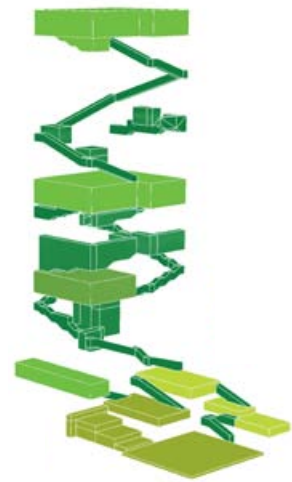

◀ **FAISAL ALANGARI B.ARCH
FOURTH YEAR STUDIO**

The Vertical Promenade in a tall building creates new program relationships and unique spatial experiences. The procession along the Vertical Promenade offers a constantly changing experience of the city. A continuous stair that begins at the street level winds through the tower culminating at the highest floor in a Public Space with a 360 degree panoramic view, which includes views of the city hall.

**SEUNG KEE KIM ▶
B.ARCH THESIS STUDIO**

"Aqua Healing Center" - The concrete channel of the LA River creates an opportunity to address the need for a rehabilitation center where mutual symbiosis between marine and human life may occur through therapeutic interaction and allow biologists and the public to access the river.

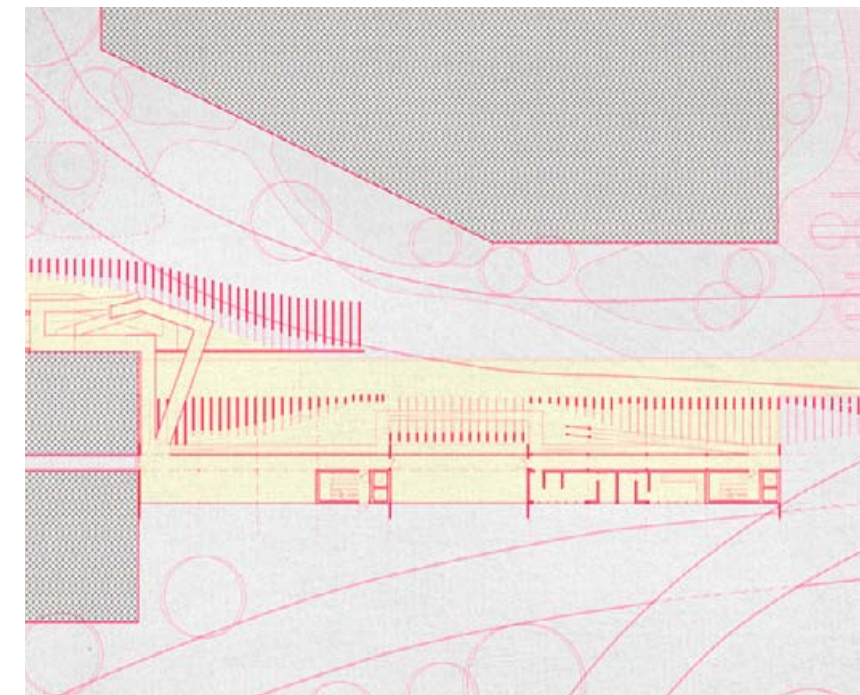

◀ **SIKHARIN CHAYARATANA
B.ARCH DESIGN STUDIO**

"Porous Barrier" - Instead of being expressed as a divider, the wall can be a porous connector of two separate and contrasting sides. The purpose of the wall in this project is to reveal what is being concealed by our own perception: the phenomenal barrier.

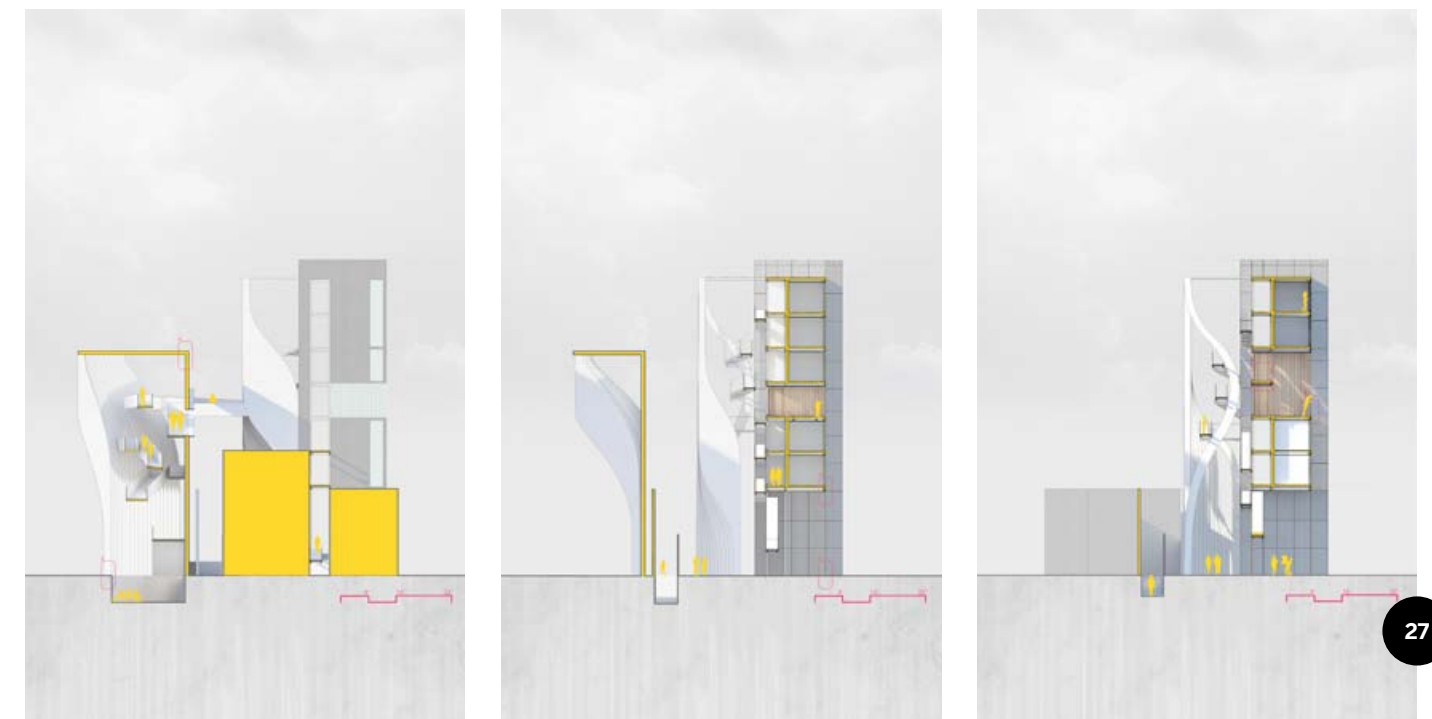

CORY SKILLMAN ▶
B.ARCH THESIS STUDIO

"LEARN Pods" - The advent of newer and quicker technologies has, ironically, begun to slow architecture down. By designing environments that are quickly fabricated, assembled, and deployed, architecture can be more respondent to its community of users as it adapts to their ever-changing needs.

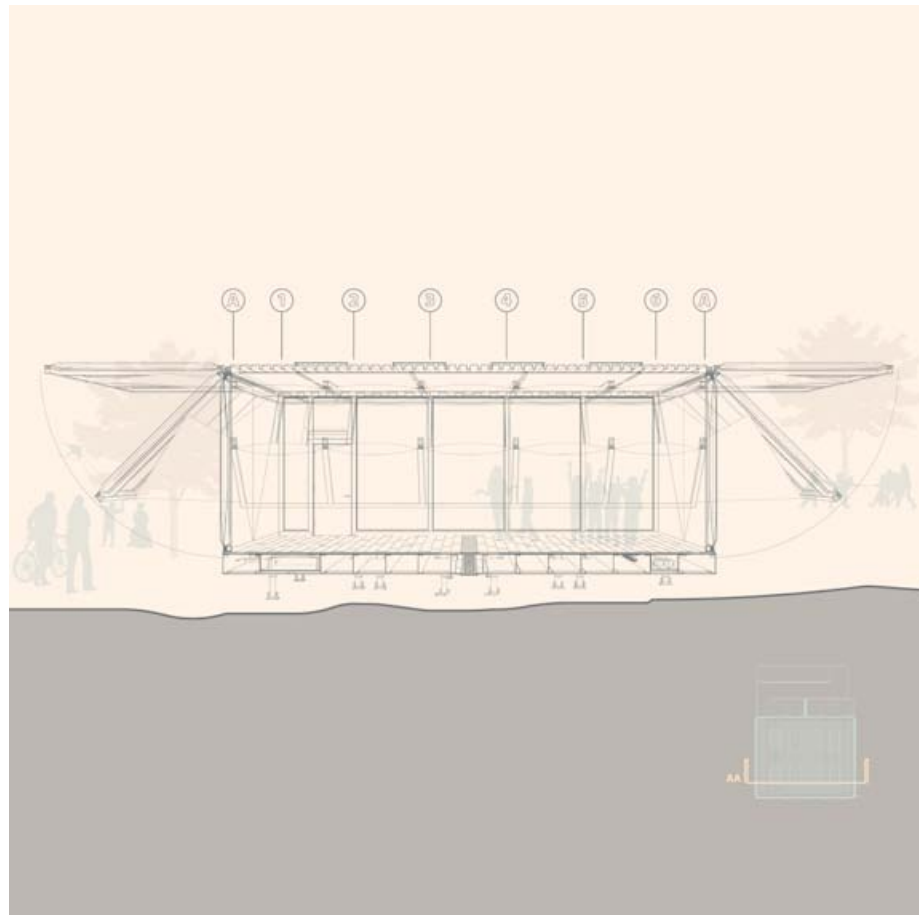
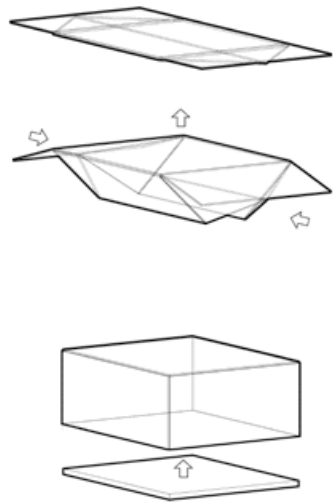

SAEED AL NEYADI ▶
B.ARCH THESIS STUDIO

"Urban Follies" - The design exaggerates sensual perception and the everyday issues we typically ignore in order to create a series of experiences through which one encounters unseen sensations. This happens by stretching the unseen and mapping its unnoticed movement through formal studies of shadows across time. In-between spaces emerge when splitting and stretching the site. These spaces do not participate in the visible world, yet they happen precisely in that location and moment where anything can occur. The follies express such moments in a way that it makes everyone aware of the unseen.

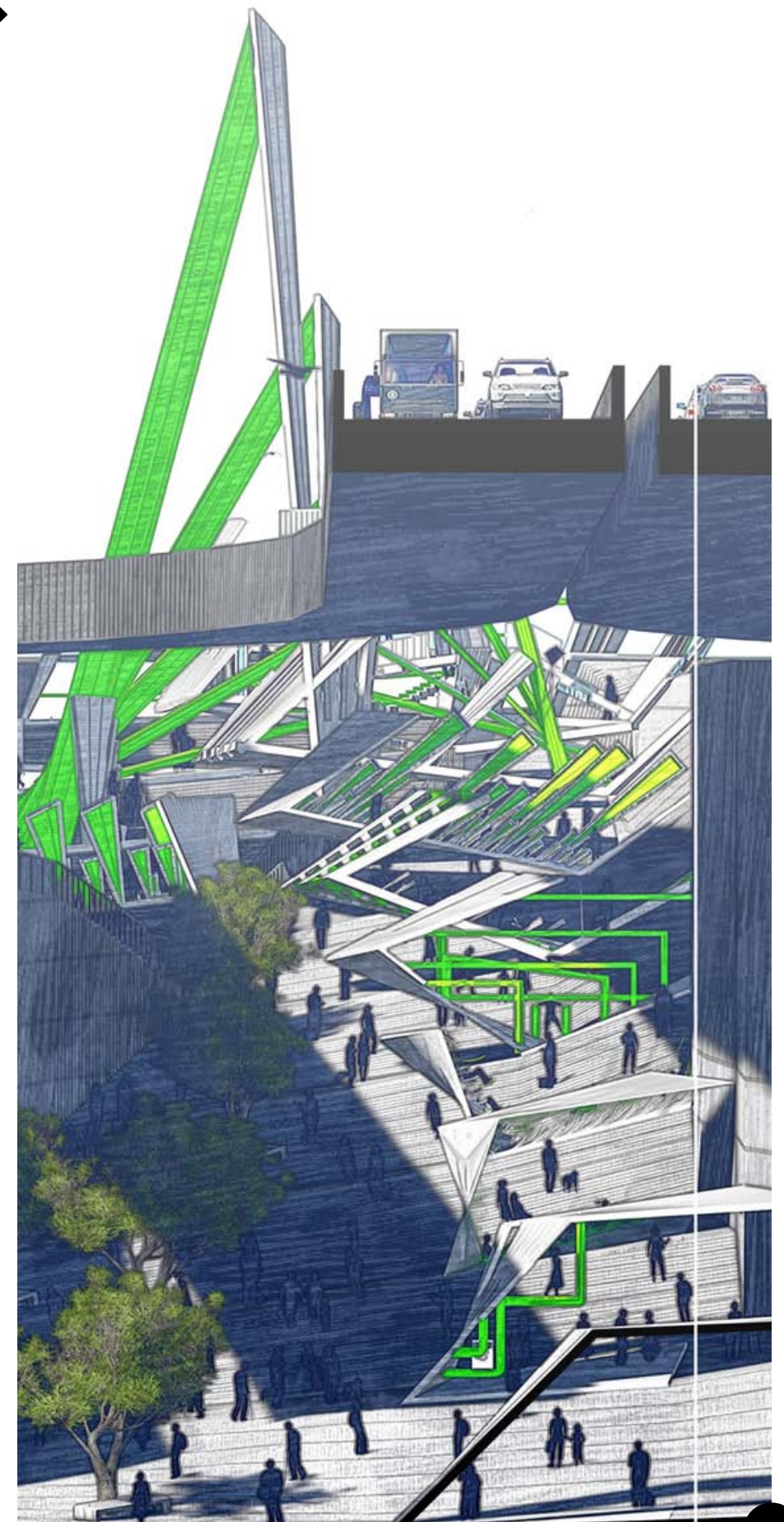
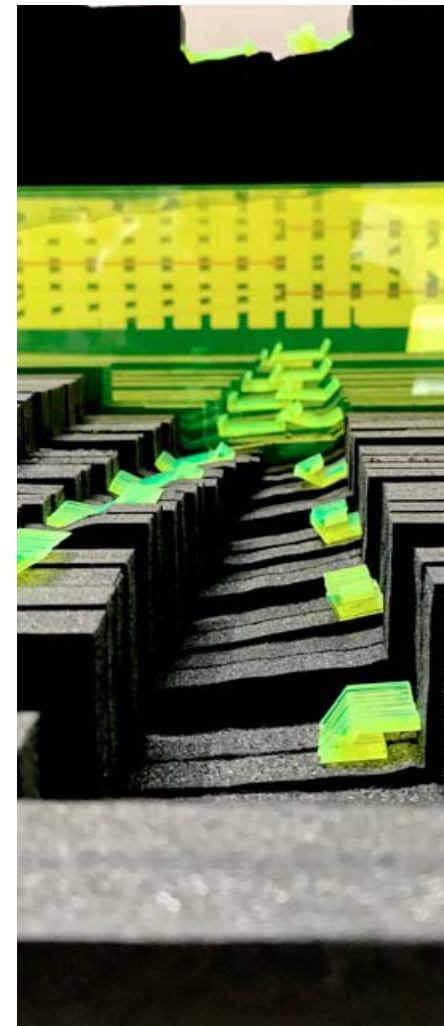

◀ JOSÉ MELARA & MOHAMMAD TALAKEY
B.ARCH 4TH YEAR HOUSING DESIGN STUDIO

"Embrace" - Transitional Housing designed for the Lower East Side of Manhattan promotes community spaces within an urban courtyard. The project was submitted to the Timber in the City student architectural competition encourages the innovative uses of wood as both structural and finish material in a multi-story project.





◀ **REBECCA MIGAN,**
B.ARCH THESIS

"Hydro-kinetic Promenade"
A hypothetical water treatment plant in middle of the LA River creates an opportunity to educate the public by designing a hydrology institution that provides research labs, exhibition, demonstration spaces and recreational areas for the public to interact with students and scientists.

JOHN CASTANEDA ▶
B.ARCH THESIS

"The Institution Behind Homes"
Harnessing the open/shared space potential of an existing parking garage in Los Angeles and breaking down the corridor/site into smaller scales, using natural light and color, and eliminating dead-ends, the thesis provides a home rather than a conventional memory-care institution.

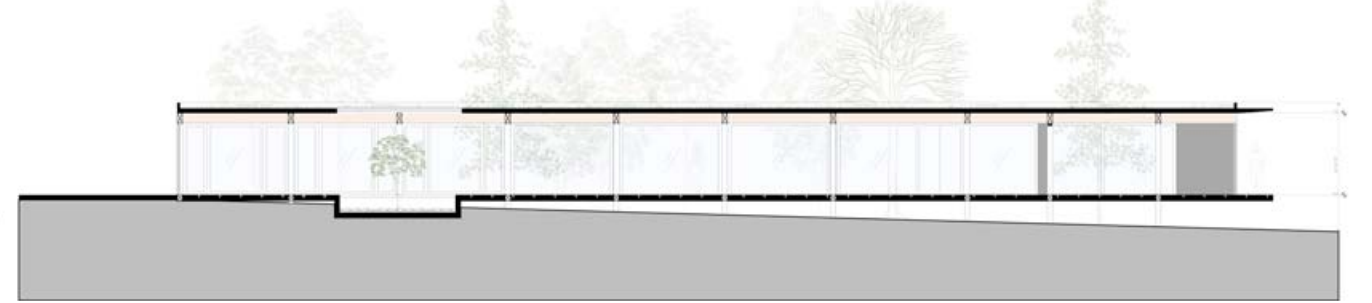

◀ **AHMAD JABASSINI**
B.ARCH DESIGN STUDIO

A new Visitor's Center at Mt. Diablo State Park gives this student the opportunity to respond to a natural site with a sensitive and compelling proposal. The design harnesses the use of daylight, changing views, materials, and structure in a subtle building that orchestrates an elongated path through the northern California landscape.

STEFAN ULTSCH ▶
B.ARCH THESIS STUDIO

"Challenging the Museum"
The traditional museum typology is challenged by the careful weaving of public and private while exploring the site as the medium of integration. At times a secluded and private process, the artists reveal their practice to the public while the architecture allows for their protection, while encouraging visual and personal interaction.





“I’ve been in this community all my life. Hunters Point is a great place, a lot of great family, great community. I would love to see this model become life in this community. The residents would really benefit from having something to sit on, for kids to play on, a place to hang out as a family and enjoy the nice scenery we have here. I think it would be great! You guys are doing a wonderful job. I hope and pray we get enough money to build what we need in order to make this community better!”

- M Latrice Manuel
Resident Services Coordinator,
SFHDC, Hunters Point East

Social Engagement

Many of our students are change makers and leaders, who are able to advocate for social equity. Engagement with issues that confront our contemporary society, particularly in the public urban context, is intertwined with the architecture curriculum supporting students with a passion to build for good.

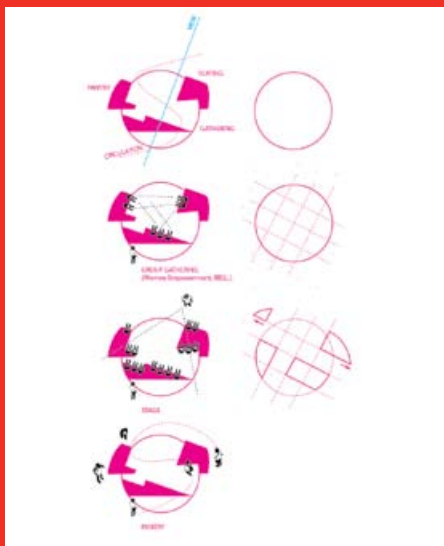

B.Lab
B.Lab is the Building Lab design/build program in the School of Architecture with a mission to cultivate and foster a spirit of diversity, equity and advocacy for future public practice among students through community-focused projects working with real clients and users.

DESIGN BUILD STUDIO
The Design Build Studio takes the mission of B.Lab into the curriculum inviting 4th and 5th year B.Arch and BA students to engage real clients and users, investigate real sites and propose and build real solutions that harness all of the skills learned in the architecture program.

GUERRILLA COFFEE UNIT
A student-built mobile coffee cart designed to serve people who are experiencing homelessness in San Francisco, creates a new safe space to converse, listen and tell stories, by giving someone on the street a literal place to sit, a warm cup of coffee, and someone to converse with.



NAAB Accreditation

Our B.Arch (162 units) and M.Arch (63 and 87 units) degrees are accredited by the National Architectural Accrediting Board (NAAB). These accredited degrees pave the way to licensure. The accredited degree represents a high educational standard and is valued within the US and beyond.

THE NATIONAL ARCHITECTURAL ACCREDITING BOARD

In the United States, most registration boards require a degree from an accredited professional degree program as a prerequisite for licensure. The National Architectural Accrediting Board (NAAB), which is the sole agency authorized to accredit professional degree programs in architecture offered by institutions with U.S. regional accreditation, recognizes three types of degrees: the Bachelor of Architecture, the Master of Architecture, and the Doctor of Architecture. A program may be granted an eight-year, three-year, or two-year term of accreditation, depending on the extent of its conformance with established educational standards.

Doctor of Architecture and Master of Architecture degree programs may require a preprofessional undergraduate degree in architecture for admission. However, the preprofessional degree is not, by itself, recognized as an accredited degree.

The Academy of Art University, School of Architecture, offers the following NAAB-accredited degree programs:

B. Arch (162 undergraduate credits)
Next accreditation visit 2018

M. Arch (preprofessional degree + 63 graduate credits)
M. Arch (non-preprofessional degree + 87 graduate credits)
Next accreditation visit 2021



Studio Culture

In architecture education the studio encompasses the learning environment, the students, the faculty and the ideas that are promoted within each project. It is a culture that supports curiosity, investigation and production. All our onsite students have their own workspace in a studio that they share with their peers during their studies.

THE STUDIO ENVIRONMENT

Both online and onsite studio environments in the architecture programs encourage public and transparent dialogue between students and faculty. Onsite students see quickly that the environment is one of open studio “classrooms” and presentation spaces in our amazing building at 601 Brannan in San Francisco’s trendy SoMA district. Online, students are engaged in discussion and activities through the online platform as well as social media and real time streaming of our events.

Beyond the architecture of our building and the connectivity of our technology, we strive to create a positive and diverse overall academic climate, supportive of group and individual discovery and learning. We promote the ideals critical to achieving a successful studio collaboration: optimism, respect, sharing, engagement, innovation, and the worth of time. The inherent value of all individuals from all backgrounds is recognized and respected.



Our Faculty

Our distinguished faculty of practicing architects is working closely with our students to investigate, explore, and advance the field of architecture and open up a world of knowledge, imagination, and exciting possibilities.



MIMI SULLIVAN
Executive Director

Mimi Sullivan, AIA, is a licensed architect in California and a principal of Saida + Sullivan Design Partners (www.saidasullivan.com). She came to the Academy of Art in 1999 as the founding Director launching the School of Architecture. She has taught architecture at the university level in the United States and in Japan. Ms. Sullivan's 25 years of diverse experience includes extensive work in award winning multi-family/mixed use housing as well as commercial, retail, civic building and custom single family homes. Mimi received her Bachelor of Arts degree in architecture from Rice University and her Master of Architecture and Master of Arts in International Studies from the University of Oregon.



MARK MUECKENHEIM
Graduate Director

Mark Mueckenheim is a licensed architect in Germany and the EU, the principal of MCKNHM Architects (www.MCKNHM.com) and the co-author of the book "Inspiration — contemporary design methods in architecture". He received his Master of Architecture from Parsons School of Design, New York, and his Graduate Diploma in Architecture at the Bartlett School of Architecture, University College London. His experience ranges from concept to realization on various projects of internationally recognized design excellence. His award winning work has been featured in various international exhibitions, books and journal publications. Mark Mueckenheim has taught and lectured internationally. He joined the Academy in 2013.



JENNIFER ASSELSTINE
Undergraduate Director

Jennifer Asselstine AIA has 30 years of experience in architecture and design and runs a design office in San Anselmo. She joined the Academy of Art University in 2004 and has been the Director of the Undergraduate program since 2012. Leading the first graduates through this program has been one of her most rewarding experiences. She earned her Bachelor of Architecture degree from University of Minnesota, where she received an award from the American Institute of Architects. She studied at London's Architectural Association and worked in the U.S., London, Malaysia and Australia on projects ranging from hotels and senior housing to an IMAX theater. She won a design award from the American Society of Interior Designers for the Red Cross Headquarters and Blood Processing Center.



ERIC LUM
Online Director

Eric Lum, AIA, Ph.D., LEED BD+C, is a licensed architect in the state of California and NCARB certified. He has taught at the Academy since 2008, and has been Online Director since 2011. He believes that online education develops critical architectural skills, as working within a networked environment increasingly becomes an integral part of professional practice. He has worked for several internationally known firms, and is a principal in his own firm. He studied architecture at the University of California, Berkeley, the Harvard Graduate School of Design, and the Massachusetts Institute of Technology, where he gained his doctorate in architectural history.



YIM LIM JEW

Assistant Graduate Director

Yim Lim Jew AIA, EDAC is a licensed architect in the state of Texas. She has been teaching since her graduate studies at the Harvard Graduate School of Design. She has held academic appointments and professorships at the Technical University of Nova Scotia, Tufts University Boston and CCA. She has worked in the Middle East and China where she also took opportunities for design teaching. She has collaborated with performance artists and along with students have created stage sets for Eth Noh Tec, and the poet Anne Carson.



KAREN SEONG

Undergraduate Assistant Director

Karen Seong is a licensed architect in California and New York, a LEED accredited professional, and NCARB certified. She developed her professional expertise while with Skidmore Owings and Merrill in New York and in San Francisco. She held leadership positions working collaboratively with large international teams on awardwinning projects ranging from high-rise to institutional buildings in the US and in the Middle East. Karen has previously taught at UC Berkeley and has been a guest critic at various institutions in the US and in Korea. She received a Bachelor of Arts in Architecture from UC Berkeley and a Master of Architecture from Columbia University with distinction.



NICOLE LAMBROU

Graduate Midpoint Coordinator

Nicole Lambrou is a registered architect in the state of New York. She received a Masters of Architecture from Yale University in 2006. She has worked in Germany with Behnisch Architekten, and collaborated on a rotating exhibition with Transsolar representing human impact on the planet throughout history. Before founding her own practice, Nicole was engaged in collaborative partnership with AE Design where she completed several houses at Sea Ranch, CA. Nicole received various accolades throughout her design career among them the second place for the design of a public library in Gevgelija, Macedonia in an international competition sponsored by the UN and the Yale School of Architecture Drawing Prize.



DAVID GILL

Graduate Architecture Advisor

David Gill is a licensed architect with over 20 years of practice. He received a Bachelor of Architecture with Distinction from California College of Arts and Crafts (now CCA). He went on to work for Kuth / Ranieri and Mark Horton / Architecture, before founding his own practice. Besides being a faculty member at the graduate school of architecture at Academy of Art University, teaching advanced design studios, thesis development and refinement, and materials and methods. He has also taught graduate design studios at CCA, and has been a guest critic at University of San Francisco, University of California at Berkeley, Cal Poly San Luis Obispo and Stanford.



MARIA PAZ DE MOURA CASTRO

Graduate Thesis Coordinator

Maria Paz is a founding partner of Rizoma Arquitetura (www.rizoma.arq.br). Her office has worked on award winning buildings and projects, which are widely recognized through numerous international publications, among them, Wallpaper, Azul Magazine, AU, Vogue Brazil, Designboom, Arch Daily, L'architecture D'aujourd'hui France, and the Financial Times, London England. Her work is exhibited internationally. Recent venues include the Brazilian Pavilion at the 2014 Venice Architecture Biennale, the Carnegie Museum of Art in Pittsburgh, and the German Architecture Museum. Paz lectured internationally in South America, Europe and the US. Her many awards include a nomination for the Mies Crown Hall Americas Prize



PETER SUEN

Graduate Emerging Technologies Coordinator

Peter Suen received a Masters of Architecture from U.C. Berkeley, where he was an Eisner Prize and Henry Adams AIA Medal recipient. As a Research Specialist, he worked on advanced facades including self-regulating membranes and microlens arrays for greywater disinfection. Before architecture, Peter worked both as an intellectual property attorney and as a software developer. He received a JD from Stanford Law School in 2002 and a Masters of Science in Computer Science from Carnegie Mellon University in 2004. Working as an architect in San Francisco, he has had the opportunity to work on a wide range of projects from tiny micro-apartment lofts to large winery developments.



DORA EPSTEIN JONES

Graduate History Theory Coordinator

Dora Epstein Jones, Ph.D., is an architectural theorist, historian and curator whose work advocates for the central role of building in architecture. She has published widely on the history of the architectural discipline, including works for Log, ArcCA, Art Papers, multiple anthologies, and on behalf of the Association for Collegiate Schools of Architecture. She is the former Coordinator of History and Theory, and the former Coordinator of General Studies at SCI-Arc, and the Executive Director of the A+D Architecture and Design Museum in Los Angeles. She is a Fellow of the American Council of Learned Societies, and a regular guest critic at the Ohio State University, USC, UC Berkeley and Harvard.



DORON SERBAN

Undergraduate Emerging Technology Coordinator

Doron Serban is a full-time faculty member and the undergraduate emerging technologies coordinator. Besides teaching, Doron Serban is a designer working in the Bay Area. Through Doron Serban Design, his professional work navigates building design, design competitions, photography, cinematography, motion design, branding, and architectural visualization. He received his graduate degree in architecture from Syracuse University's School of Architecture and his undergraduate degree in music from the University of California, Riverside.

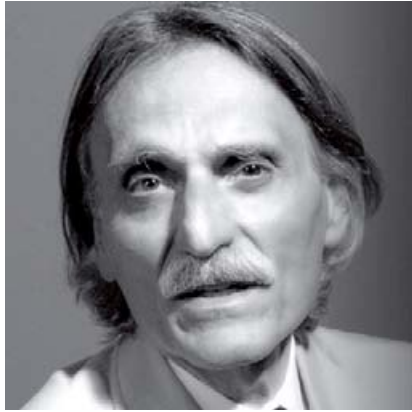

ALBERTO BERTOLI

Chair Emeritus

Mr. Bertoli has vast experience in different areas of the architectural profession. His work ranges from the planning of shuttle facilities for the space program to the designing of a performing arts center. He most recently designed the InterContinental San Francisco hotel. His work has also been recognized by multiple AIA Chapters, the Architectural Association of France, and at numerous international competitions. Mr. Bertoli started his formal education at the University of Buenos Aires, and continued at Cal Poly San Luis Obispo. He has his professional license through the State of California. Before joining the Academy he was a lecturer at Cal Poly SLO, UCLA Graduate School of Architecture, and taught for more than 20 years at SCIARC.



BRADEN ENGEL

Undergraduate Architecture History & Theory Coordinator

Braden Engel is a full-time faculty member and undergraduate history theory coordinator. He has taught internationally – at the Architectural Association, London, the University of Greenwich, London, and he was a Senior Lecturer in Architecture at California College of the Arts, Lecturer in Architecture at UC Santa Cruz and at the University of California Berkeley before joining Academy of Art University. Braden received an M.A. in Histories & Theories of Architecture from the Architectural Association, London, and an M.Arch. and a B.S. in Philosophy from North Dakota State University. His written work has been published in the United States and abroad.



ALEX NEYMAN

Undergraduate Collaboration, Communication & ARH 210 Coordinator

Alexandra Neyman holds both a Master of Architecture and a Bachelor of Science in Architecture from the University of Michigan. She also attended School of Art and Design at the University of Michigan, as well as Center for Creative Studies in Detroit, MI, and Schusev's School of Art and Design in Russia. Alex's academic interests and experimental research aim to integrate theoretical morphological studies, actively utilizing data from a wide range of sources, her work aims to generate new principles for design and invent new spatial logics and organizations that have an influence on physiologies of form.



VAHID SATTARY

Undergraduate Structures Coordinator

Dr. Vahid Sattary is a California Registered Structural and Civil Engineer and the principal of Sattary Structural and Earthquake Engineering. He has over 25 years experience in structural engineering and seismic design including the state-of-the-art design of seismic protective systems, base isolation and energy dissipation application in buildings. He has been the structural engineer for many projects including new building designs, seismic retrofit of historic buildings, and structural evaluation studies. Vahid Sattary received his BS in Civil Engineering at the Illinois Institute of Technology, Chicago and his MS in Civil Engineering at the University of Michigan, Ann Arbor where he later also obtained his Ph.D. in Structural Engineering.



SAMEENA SITABKHAN

Community Outreach Coordinator

As a licensed architect, Sameena has designed and managed a range of building typologies over the past 15 years. Her practice pinkTank (www.pinktank.xyz) and research looks at the intersection of architecture and conflict, and she's been an artist and curator in residence in Mexico, Decolonizing Architecture in the West Bank, and most recently as a fellow at the YBCA. Formerly an Associate at David Baker Architects, designing and managing affordable housing projects, Sameena is currently studio faculty and the B.Lab Coordinator. She is focused on creating opportunities for student engagement in community based projects, including making with an emphasis on advocacy. Sameena has an undergraduate degree in Urban Planning from the University of California, San Diego, and a Masters Degree in Architecture from SCIARC in Los Angeles.



EVA CHIU

Undergraduate First Year Studio Coordinator

Eva Chiu was born and raised in New York City. She received a Bachelor of Architecture from Massachusetts Institute of Technology and a Master of Architecture from Harvard University, Graduate School of Design where she was granted the Alpha Rho Chi award. Eva's academic achievements included a Fulbright Award followed by a Fulbright Fellowship in Hong Kong, PRC. She worked previously at Richard Meier & Partners in New York, and Skidmore Owings and Merrill in San Francisco before starting her own firm, Clad Studio (www.cladstudio.com) with her partner, Antonio Lau, in Oakland, California. Before joining the first year design studio faculty at the Academy of Art University, Eva taught at University of California Berkeley and was a guest lecturer and reviewer at other institutions in the US and abroad.

Additional Adjunct Faculty:

School of Architecture Faculty Roster 2016-2018:

Paul Adamson, Jesse W. Agosta, Vivek Annand, Jason Austin, Lise Barriere, Simon Battisti, Janek Bielski, Alvaro Bonfiglio Bardier, Laura Brugger, Carol Buhmann, Abraham Burickson, David Campbell, Blaise Cannon, Mini Chu, Benjamin Corotis, Mark Cruz, Mallory Cusenbery, Benjamin Damron, Jaime Daroca, Stephanie Davidson, Chris Kelton Dissel, Shruti Dixit, Mark Donahue, Lionel Eid, Cesar Escalante, Goetz Frank, Peter Gang, Miranda Gardiner, Alexa Getting, Geoffrey Gibson, Stewart Green, Julia Grinkrug, Steve Gross, Kevin Hackett, Bo Han, Madeline Hartzell, Alexander Hathaway, Drake Hawthorne, Paul Haydu, Michael Heacock, Paul Jamtgaard, J. Hulett Jones, Peter Kimelman, Joseph King, Stamatina Kousidi, Antonio Lao, Amy Leedham, Mei Kuen Liu, Michaela MacLeod, Sepideh Majidi, James Mallery, Katy Martin, José Mayoral Moratilla, Jeffrey McLane, Zachary Meade, Shaum Mehra, Joel Millar, Clifford Minnick, Mark Myers, Jonathan Odom, Nathan Ogle, Patrick Ojeda, Francesca Oliveira, John Onken, Edward Pertcheck, Sara Peschel, Christopher Pizzi, Keith Plymale, Philip Ra, Eric Reeder, Benjamin Rice, Joseph Paul Rivers, Hans Sagan, David Schragger, José Ramón Sierra y Gómez de León, Peter Strzebniok, Carlo Sturken, Fumio Suda, Susan Sutton, Sannihita Takkallapalli, Elizabeth Tippin, Vasilena Vassilev, Carl Wilford, Archibald Woo, Ethen Wood, Bill Worthen, Vince Yueh.

Faculty Work

Our faculty accumulates a wealth of experience in the design and execution of outstanding buildings across the globe. The following pages only show a very small selection of recently completed buildings and designs by our faculty members.

MIMI SULLIVAN ▶
SAIDA + SULLIVAN
DESIGN PARTNERS
EXECUTIVE DIRECTOR
SCHOOL OF
ARCHITECTURE

Saida + Sullivan's mission is to achieve a "sense of place" through the craft of architecture. The firm is well known in the Bay Area and beyond for high quality housing projects with an emphasis on social housing. The firm is certified by the San Francisco Human Rights Commission.



ALTEZZA - Oakland, CA - Photo: Rien Van Rijnhoven



Mission Bay Block 11 - San Francisco, CA - Photo: Eric Rorer

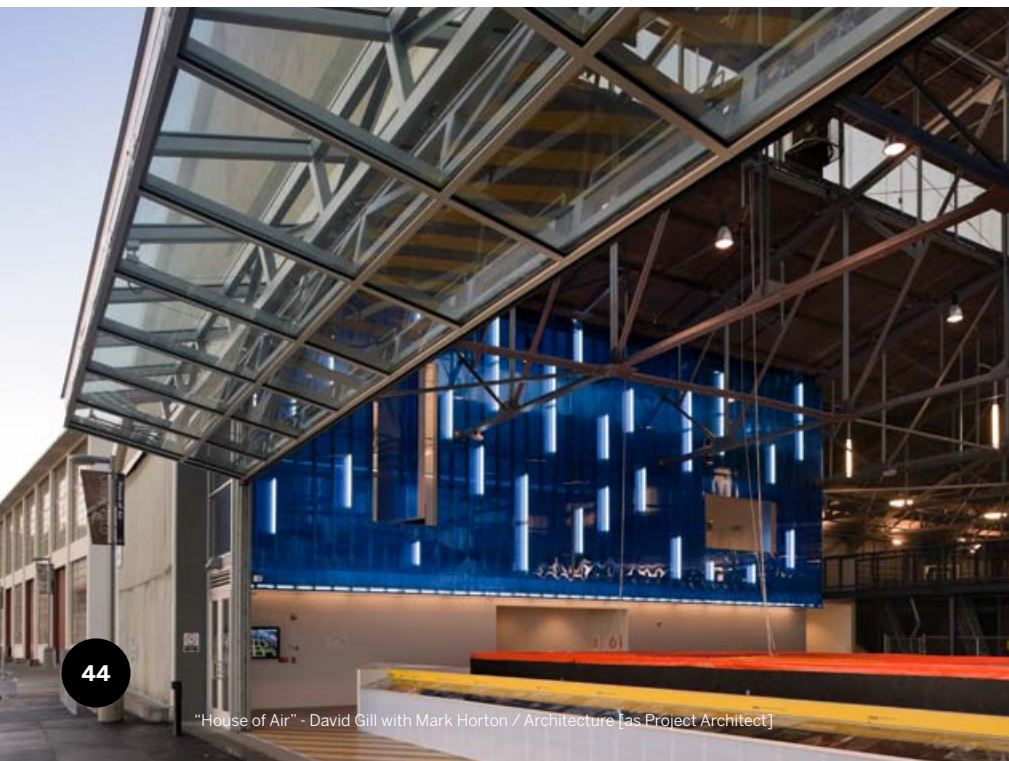

"House of Air" - David Gill with Mark Horton / Architecture [as Project Architect]

◀ DAVID GILL - GRADUATE
ARCHITECTURE ADVISOR
AND FULL-TIME FACULTY

David Gill is a licensed architect with over 20 years of practice. He has many years of experience in firms like Kuth / Ranieri, Mark Horton / Architecture, before founding his own practice. He now directs an interdisciplinary and collaborative design studio committed to developing the process of making things. He is currently involved in multiple projects in Oakland and Berkeley.

MICHAELA MCLEOD ▶
POLYMETIS

HotBox - The Beaches Park, Toronto, Ontario, Canada (with partner Nicholas Croft www.polymetis.net). HotBox mimics a typology and heightens the contrast between inside and outside, allowing visitors to experience warmth in a variety of associative means, while acting as a catalyst for interaction during Toronto's Winterstations Festival. The installation Pink Punch attracts visitors by its striking color, off the beaten path, and into the forest.



"HotBox" - The Beaches Park, Toronto, Ontario, Canada



"Pink Punch" Installation at Jardin de Métis - Grand-Métis - Québec, Canada

PETER STRZEBNIOK
NOTTOSCALE

The Rondolino residence is a prefabricated, modular housing prototype. Due to its remote location, the home is completely independent from traditional public amenities and services, integrating sustainable building systems, design materials, and alternative renewable energy sources.



Rondolino Residence - Scotty's Junction, Nevada - Photo: Joe Fletcher



◀ **STEWART GREEN**
MICROSOFT CAMPUS
PROJECT ARCHITECT
WRNS STUDIO

The expansion of the campus plan emphasizes sustainable solutions, collaboration and health and wellness. A creekside environment, green roofs and new opportunities for sport, exercise and fitness are integrated into this complex modernization of the corporate property in Silicone Valley. Stewart brings his expertise in large integrated projects into the 4th year design studio where he skillfully guides the student work.

Microsoft's New Silicon Valley Headquarters - Rendering: WRNS Studio

GOETZ FRANK ▶
LEAD PROJECT ARCHITECT
SF-JAZZ CENTER MARK
CAVAGNERO ASSOCIATES

The SFJAZZ Center is the first freestanding venue in the US designed specifically for the performance, appreciation and enjoyment of jazz. The Center, which opened in January 2013, establishes a hub of music, culture, and community.

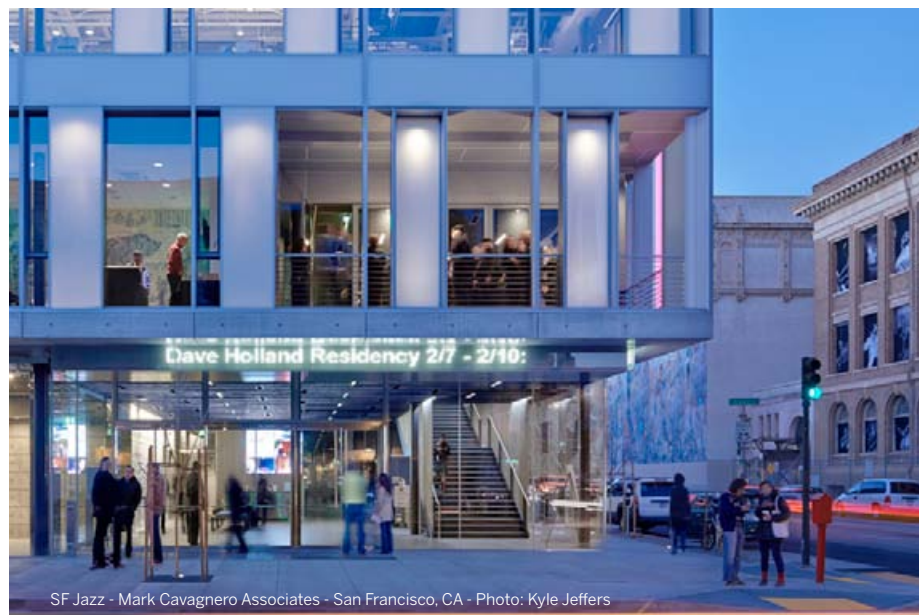

SF Jazz - Mark Cavagnero Associates - San Francisco, CA - Photo: Kyle Jeffers



SF Jazz - Mark Cavagnero Associates - San Francisco, CA - Photo: Tim Grimm

SIMON BATTISTI ▶

Simon Battisti, Leah Whitman-Salkin, and design collective Åbåke represented Albania at the 15th International Biennale in Venice, Italy in 2016, with their project entitled, "I Have Left You the Mountain," which seeks to "evoke places and loss through polyphonic singing, or multi part lyric," and to display a theme of displacement and migration, prevalent in Albanian history, and recent European events.



"I have left you the Mountain" Installation view - Venice Biennale 2016 - Photo: Špela Volčič



Cafe Fargo - Buffalo, NY - Photo: Florian Holzherr

◀ **STEPHANIE DAVIDSON**
DAVIDSON RAFAILIDIS

Stephanie Davidson's and Georg Rafailidis' studio is focused on designing tight projects with equally tight budgets. They have won competitions and awards, and have been published in books, journals and magazines internationally.



He, She & It - Buffalo, NY - Photo: Florian Holzherr



◀ **JENNIFER ASSELSTINE**

Jennifer's thirty years of practice have spanned all scales, many typologies and most continents. Recent work has been focused on the deep commitment to collaboration and community-focused projects. In partnership with clients, users, makers, designers and builders there exists an opportunity for design-thinking and communication to enhance the value of architecture in the service of the inhabitants.



Stone and Wood House - Knolls, CA with Antje Paiz

JASON AUSTIN ▶
SURALARK - SOCRATES
SCULPTURE PARK,
QUEENS, NY
AUSTIN+MERGOLD LLC

SuralArk is an American vernacular interpretation of the original Noah's vessel. It has its formal roots as a (discarded) upturned ship cast ashore. Jason utilizes his dual degrees in Architecture and Landscape Architecture in the development of his practice Austin+Mergold and in the design studio with his students.

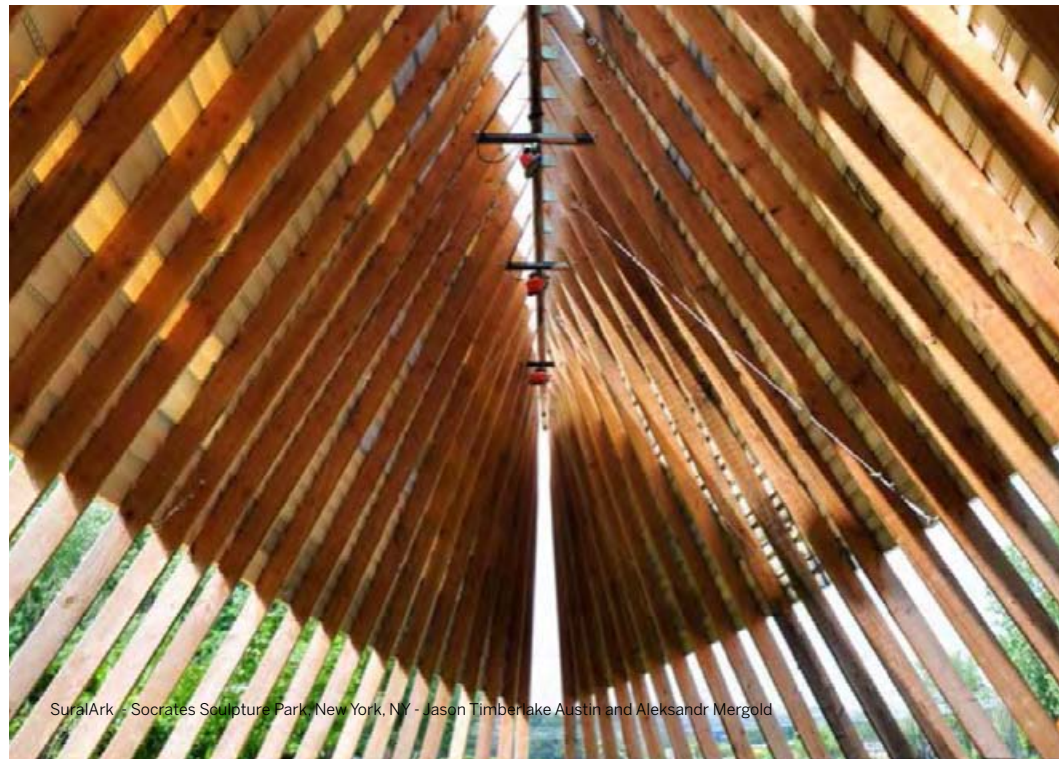

SuralArk - Socrates Sculpture Park, New York, NY - Jason Timberlake Austin and Aleksandr Mergold



International Antarctic Center - Competition - Punta Arenas, Chile

▶ **PRÁCTICA**

Jaime Daroca Guerrero, José Mayoral Moratilla, and José Ramón Sierra Gómez de León are PRÁCTICA. The partners met at the GSD and run their successful office in Spain and Chile, they are all teaching at the School of Architecture.



Training and Employment Building -Granada, Spain - Daroca Arquitectos - Photo: Fernando Alda

◀ **JAIME DAROCA**
DAROCA ARQUITECTOS
 Project Architect at Daroca
 Arquitectos Employment Building,
 Baza, Spain.

JONATHAN ODOM ▶

Jonathan is a designer maker, and artist. After studying architecture, curiosity and a dedication to making has led him to explore a diverse range of disciplines including film, special effects, animatronics, custom homes, interactive museum exhibits, furniture, parklets, and industrial design. Besides being a dedicated teacher, Jonathan is a full-time member of the Instructables Design Studio at Autodesk where he experiments with CAD design and digital fabrication.

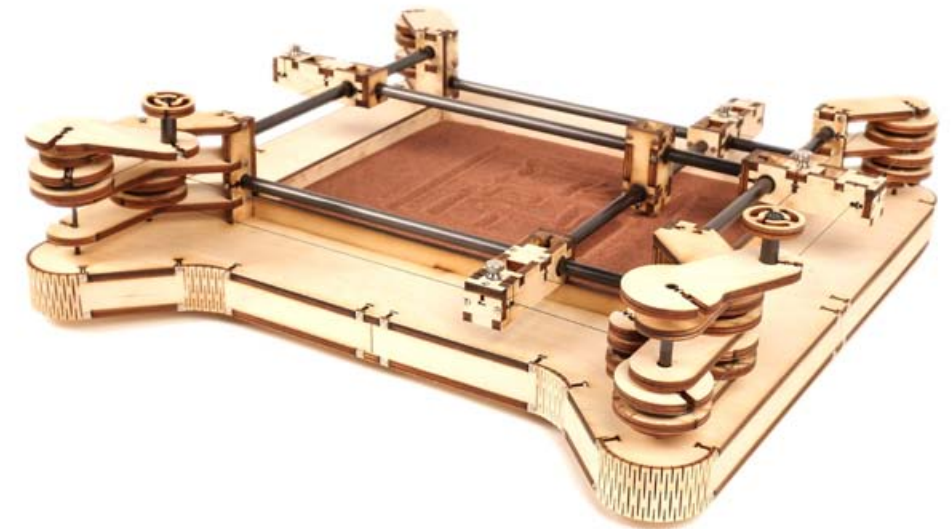

Jonathan-Odom--XYZen-Garden

**PHILLIP RA ▶
CJ ONLY ONE R&D CTR
SEOUL, KOREA
LEAD DESIGNER
YAZDANI STUDIO
CANNONDESIGN**

Philip's research and passion for both experimental design and technology was fostered at USC and Harvard GSD, and remains evident in his design leadership today across many project types. His passion for both architecture and digital technology has lead him to be an absolute innovator.



CJ Blossom Park - Gyeonggi-do, South Korea
Yazdani Studio of CannonDesign and Heerim Architects



Restaurante Oitica - Inhotim, Brumadinho, MG / Brasil



Galeria Tunga - Inhotim, Brumadinho, MG / Brasil

**◀ MARIA PAZ DE
MOURA CASTRO
RIZOMA ARQUITETURA**

Maria Paz's office Rizoma bases its work method on the idea of a rhizome, a botanical root system. Unlike the root of the vertically growing tree, the rhizome has no hierarchical structure, it functions as a network. Her office therefore operates in a constant form of knowledge exchange, where the objectives are mutant and the premises negotiable.

**MARK MUECKENHEIM ▶
MCKNHN ARCHITEKTEN**

MCKNHN is an award winning architecture and design firm. The work focuses on architectural and urban planning projects that cover a diverse range of typologies, scales and locations. The collaborative and analytical process, follows a research and concept driven design approach as well as a comprehensive design strategy. Mark Mueckenheim's work has been featured in various international book and journal publications and has also gained reputation through a number of international exhibitions.

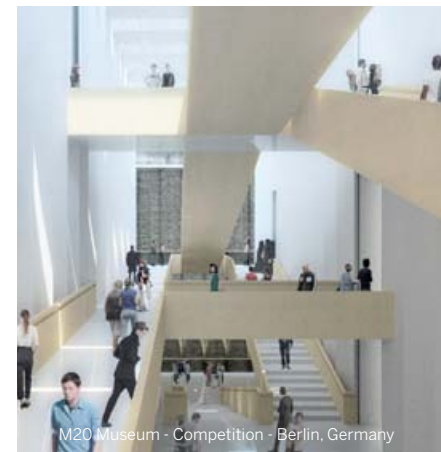

M20 Museum - Competition - Berlin, Germany

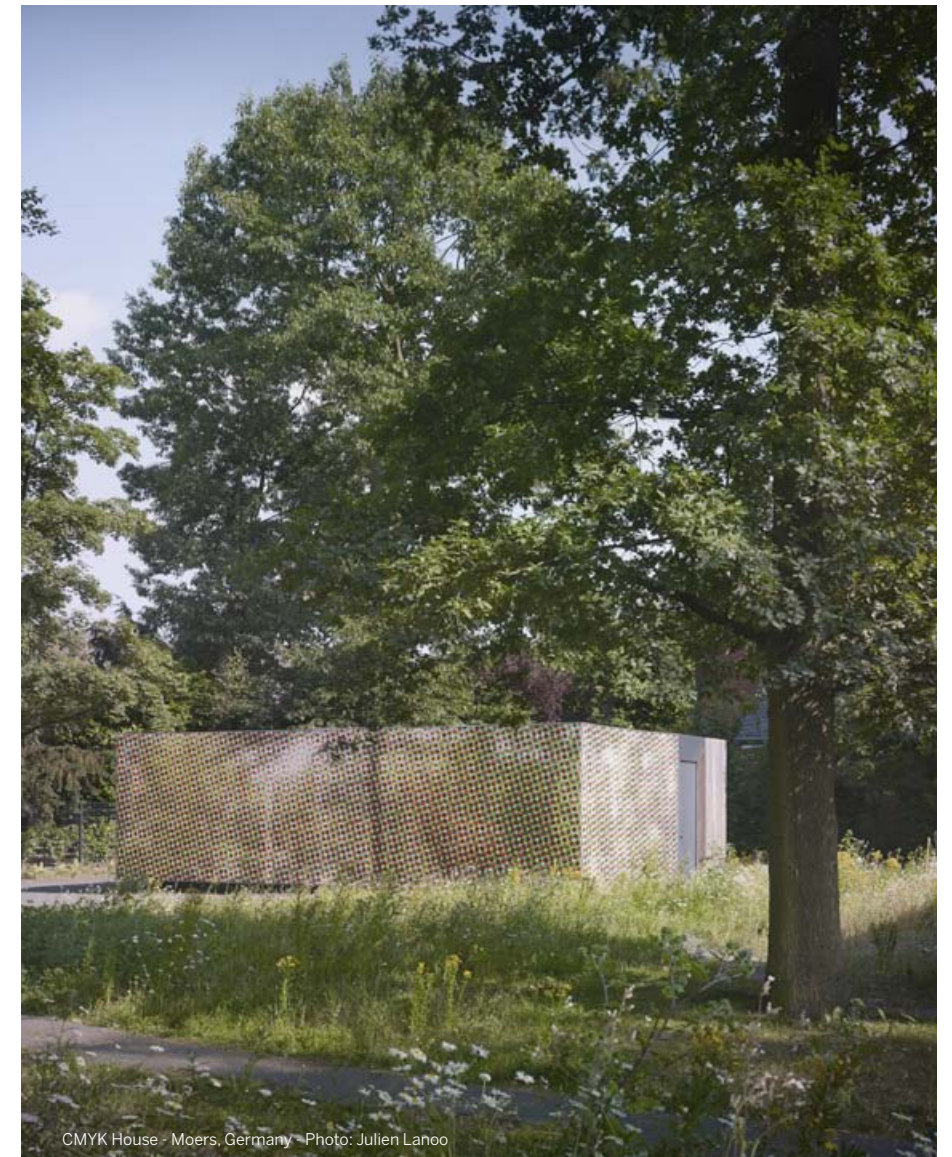

CMYK House - Moers, Germany - Photo: Julien Lanoo

**BENJAMIN DAMRON ▶
WAYNE MORSE FEDERAL
COURTHOUSE
HEAD DESIGNER FOR
MORPHOSIS
ARCHITECTS**

As a senior designer at Morphosis, Ben designed award-winning projects. Since then he has engaged his design skills and focused interest in material use and the impact on experiential space across all scales – designing large towers for SOM and most recently at the award-winning design firm, Aidlin Darling Design.

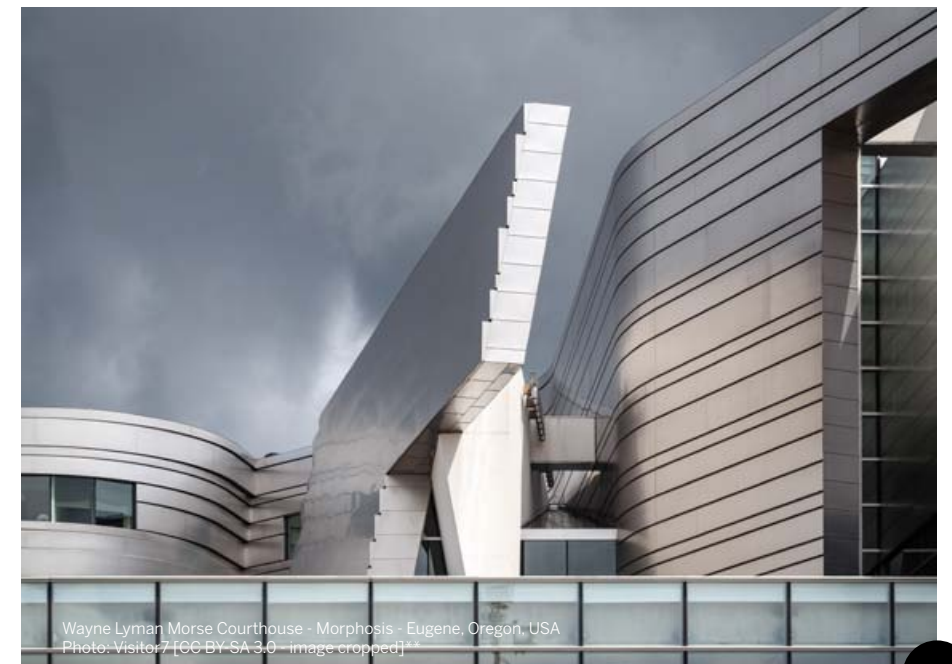

Wayne Lyman Morse Courthouse - Morphosis - Eugene, Oregon, USA
Photo: Visitor7 [CC BY-SA 3.0 - image cropped]



ROBOTICS LAB

Our robotics lab is exploring emerging methods of representation and fabrication within architecture and design. As robot technology is rapidly advancing within architecture practice, we conduct hands-on research by design tied to the profession and potential building applications which innovate the field.



WOOD SHOP

Our fully equipped wood-shop facilities include a full array of hand tools, table saws, drill presses, and a host of other tools. The shop is staffed by qualified shop technicians that support students in realizing a wide array of projects: from an intricate architectural model, to a custom furniture piece, or even larger installations.



METAL SHOP

The metal shop expands students' opportunities to realize their projects and explore the potentials of different material expression and technique. Students have the opportunity to learn a variety of metal fabrication processes.



FABRICATION LABS

Advanced digital fabrication equipment including laser cutters, 3D printers, and CNC routers among many others are deeply embedded into our curriculum. Students learn to use these tools and apply them into their design process.

The School of Architecture is committed to continuously updating the physical production facilities of the school to accommodate and address the advancing field of architecture and the built environment.



Our Facilities

Experience physical building design with our fully equipped professional wood shop, emerging digital fabrication tools, and design studio spaces that closely replicate the culture of contemporary architectural profession.



CONTEMPORARY ARCHITECTURE STUDY ABROAD

This seven week class focuses on contemporary built works of architecture culminating in an intensive two week travel throughout central Europe. The comprehension of these seminal buildings will be supported through discussions, guided tours, and lectures on site.



Photo by Petar Milošević [CC BY-SA 4.0 License - image cropped]*

ART AND ARCHITECTURE OF THE RENAISSANCE

The AAU seven week residency summer abroad program in Florence, Italy invites architecture students to experience the art and architecture of the Renaissance in Italy. Students will share fine art and history courses with students from other schools within the Academy of Art University.



PRE-COLLEGE PROGRAM

Academy of Art University offers a scholarship based Pre-College program available to all current High School students proficient in English. Scholarships cover tuition costs of up to 2 classes for Fall/Spring and up to 4 classes for Summer semester.

Special Programs

Experience architecture through our intensive and exciting special programs that are designed to introduce or deepen the understanding of the built environment and how we as architects shape this experience.



“It was helpful to see material fabrication and assembly on an actual construction site. It is one thing to talk about building construction in the class room but another to see it in person on site.”

- Kenta Oye - B.Arch



New York field trip.

“Walking through the wheat field you hear the buzz of the insects around you ... it was idyllic. Then you take a turn and you see there are people from all over the world who have come to see this teeny tiny little chapel, and you walk in and you have goosebumps.”

- Michelee Alvarez - M.Arch

“Taking the study abroad was a transformative experience. I gained architectural knowledge that would have taken years to acquire and it was a giant leap forward for my reading of spaces and functions of buildings.”

- Daniel Toledano - M.Arch Online

“Then we went into the Rotterdam Market Hall and it was just ... the hair stands up on your arm. It was amazing, like a party, there were people meeting for dinner and people tasting food. It was so much different than what we had assumed.”

- Michelee Alvarez - M.Arch

“It was an mind-opening experience. Although I've done in-depth research about the buildings before we went, I was still shocked, the moment I stood in front of them: the visual impact, the touch of the materials, the effect of light, the movement of people, and even smells sometimes, were all out of my expectation.”

- Ying Wang - M.Arch

Contemporary Architecture Study Abroad

Field trips are an important component of any architectural education. Our Contemporary Architecture Study Abroad Course is a one-of-a-kind multi-city field trip in July and August that investigates many outstanding contemporary buildings, urban centers, and spaces. We also incorporate office visits of world renown architects in Europe.

The Foreign Study focuses on contemporary built works of outstanding architecture, landscape architecture, interior and urban design, and art, the conceptual meaning of these examples and their role in recent architectural discourse. The course cumulates in an intensive site visit, throughout a particular region in Europe. The comprehension of the architectural precedents that we will be visiting, will be supported through discussions, guided tours, walking tours and lectures on site. Every other year, we also visit the Venice Architecture Biennale to see this most important exhibition of architecture in the world.

“Architecture (Buildings) Culture, Food, we had so much to say to each other.”

- Chi Li - M.Arch

“... it is so hard to truly understand a building without visiting it in person.”

- Ying Wang - M.Arch



Bjarke Ingels Office Visit



Bjarke Ingels Office Visit



Zaha Hadid's Office in London



Herzog and De Meuron - Basel



David Chipperfield - Berlin Office

OFFICE VISITS

In the last years we were able to visit offices of world famous architects and experienced their work methods and philosophies first hand. Offices that we visited included: Bjarke Ingels Group [BIG] in Copenhagen, Denmark (above and left); Herzog and De Meuron in Basel (below center), Switzerland; David Chipperfield in Berlin (below), Germany; Zaha Hadid in London, England (below left).



The Mountain - Bjarke Ingels Group



De Rotterdam - OMA Rem Koolhaas



Thermal Baths, Vals, Switzerland - Peter Zumthor



Venice Architecture Biennale visit 2016

OUTSTANDING WORK FROM WORLD RENOWNED OFFICES

The Contemporary Study Abroad visits buildings of world renown architects. You can expect to see the best of the best of architectural examples in the world. Recent trips have included works by Peter Zumthor, Bjarke Ingels, Rem Koolhaas, MVRDV, SANAA, Zaha Hadid, Herzog and De Meuron, David Chipperfield and many others. Additionally, you will be able to experience buildings of young architects who are considered up and coming during the next decades.



Design School Zollverein [usually inaccessible] - SANAA

UP TO DATE

The course continuously features buildings and issues that are currently being discussed in architectural media and that are front and center of contemporary architectural discourse. As a student you can expect to be able to participate in understanding these issues through your first hand experience of buildings. Most buildings we will visit are completed in the last 10-20 years. Some might be older and a few are just completed months or even weeks before we visit them.



Art & Architecture of the Renaissance in Florence Study Abroad Residency Program

This immersion study-abroad course based in Florence, Italy each summer introduces students to the primary works of Renaissance art and architecture. Visits to key buildings, collections and museums, as well as lectures, sketching assignments, and written essays, will expose students to the rich history and influence of Florence's Renaissance past.

“In Florence, I started to really experience buildings. Now, I cannot go anywhere without looking up, looking around and analysing the buildings that surround me. It got me out of the places I know and into a new environment with new people and friends.”

- Juliana Bento - B.Arch

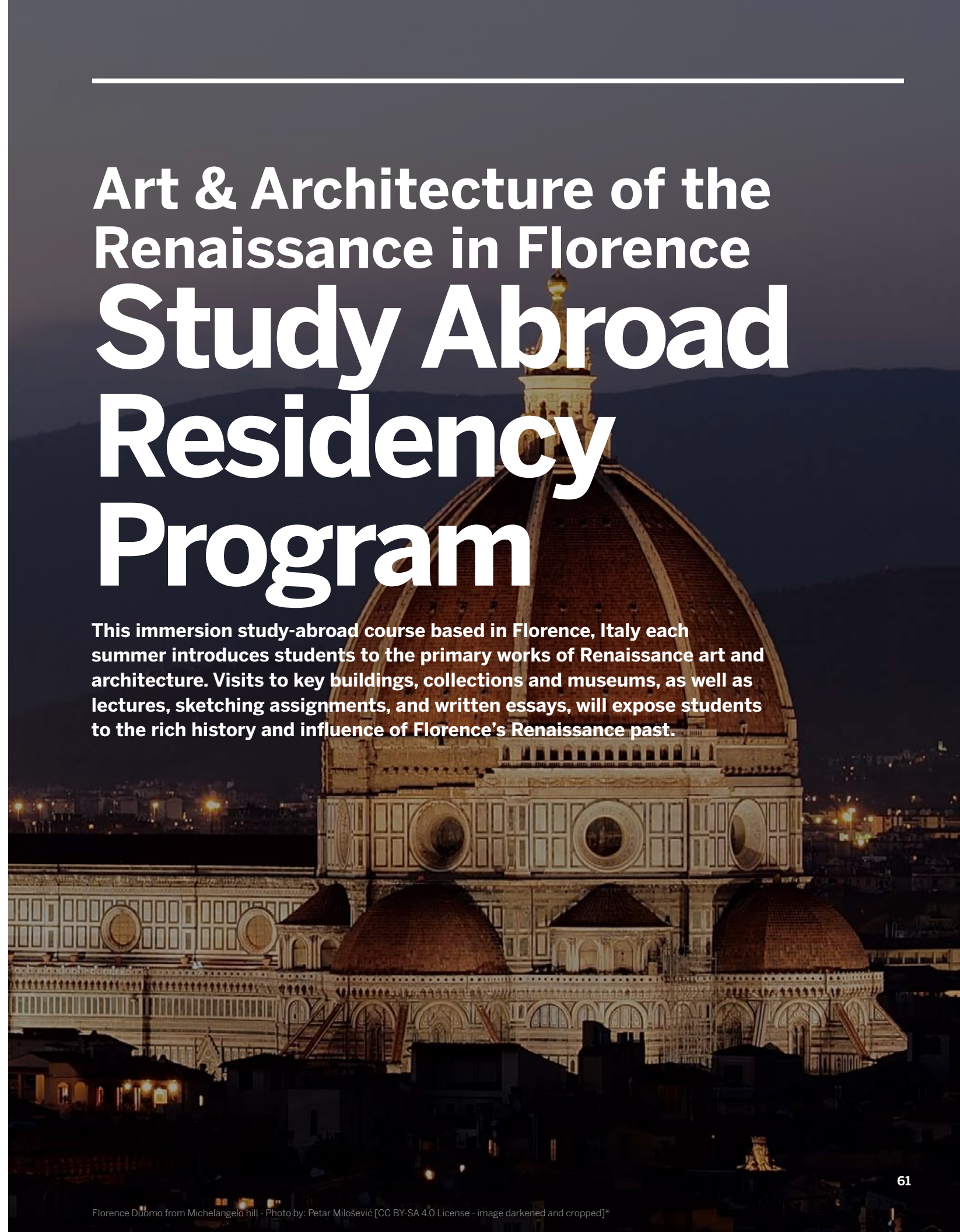
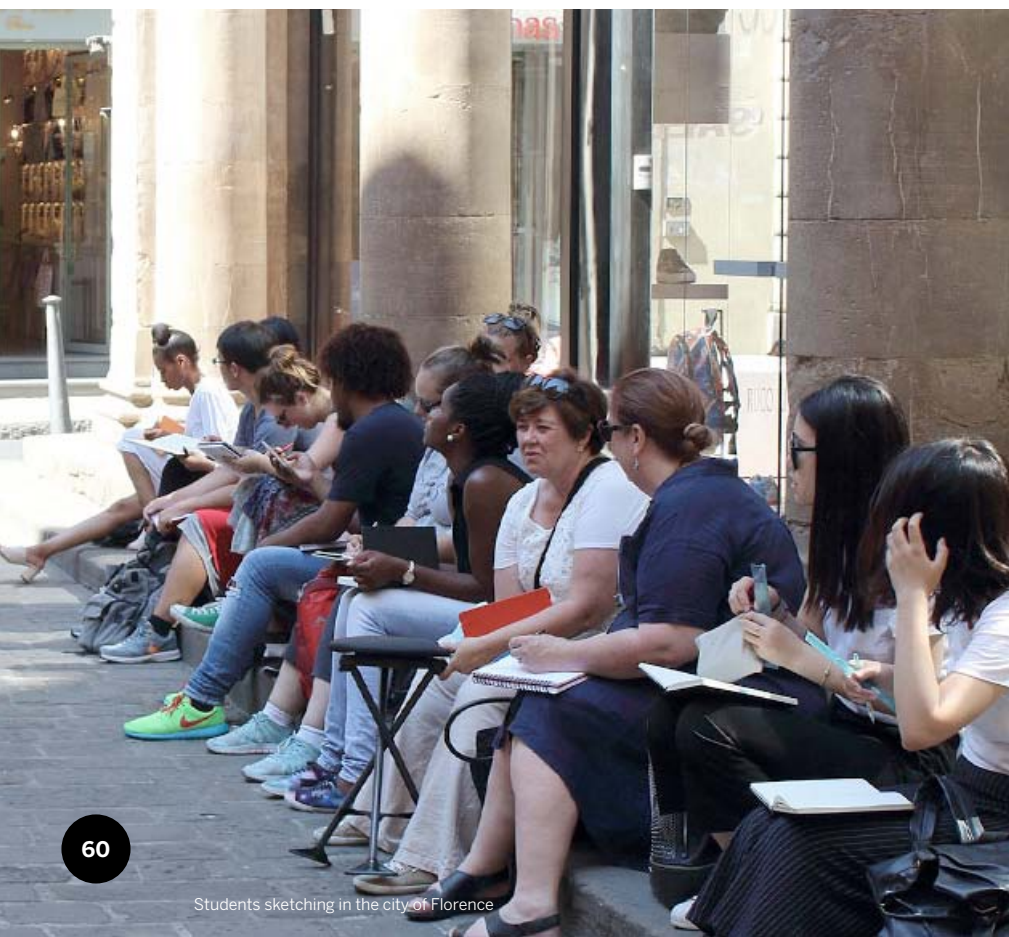



Ethics and Leadership Panel Discussion



WORKSHOPS AND SPECIAL EVENTS

We hosted the Architectural Association's Summer School program where our students built a large interactive cloud (see below). Our students supported the Market Street prototyping festival in the fabrication of a public climbing wall installation (above).



PANEL DISCUSSIONS AND DESIGN CHARRETTES

Design Charrettes with distinguished guest architects that lead student collaborative teams (above) and the bi-annual Ethics and Leadership Panel (top image) introduce students to design issues in our city that rely on our vision.



LECTURE SERIES

Our international lecture series brings a diverse mix of highly distinguished guests and interesting young practices to our school to engage with faculty and students and to talk about their work. Recent speakers include: Frank Barkow (Barkow Leibinger - Berlin) / Michael Bell (Bell Seong Architecture - New York) / Peter Busby (Perkins and Will - San Francisco) / Sir Peter Cook (Crab Studio - London) / Neil Denari (NMDA) / Sascha Glasl (spaceandmatter - Amsterdam) / Andrés Jacques (Andrés Jacques Architects - Madrid) / Wes Jones (Jones Partners) / Georg Rafailidis (Davidson Rafailidis) / among many others.



Public Events

Our culture is enriched through the events that take place outside of the architecture studio and classrooms connecting us to prominent practitioners and the current design dialogue.





688 AND 625 SUTTER

Located along downtown San Francisco's Sutter Street gallery row, 688 Gallery and nearby 625 Gallery form a mini-destination for art enthusiasts.

CANNERY GALLERY

Located on 2801 Leavenworth St. and adjacent to the Golden Gate Bridge this gallery is a prime location also frequented by many tourists. Architecture students can submit work for inclusion in a gallery show.



ANNUAL SPRING SHOW

The annual Spring Show at the end of every Spring Semester is a major event. The accomplished work of selected Academy of Art University students is in the spotlight at the annual Spring Show Student Showcase. The show features all departments and schools of the Academy and is therefore held in a giant warehouse to encompass all the exciting work that is on view. The opening night attracts literally thousands of visitors. The School of Architecture invites architects from all over the world to come to this exciting event and students have the chance to show their work and engage with them on opening day. This show is truly a great exposure for our students. Past invitees were architects from offices like David Adjaye Associates, David Chipperfield, Bjarke Ingels Group, and many more.



AIA ARCHITECTURE + THE CITY FESTIVAL

SCHOOL OF ARCHITECTURE GALLERY SHOW AT THE ATELIER

Atelier 79 New Montgomery St.

Every Fall Semester in September the School of Architecture participates in the AIA Architecture and the City Festival that is running annually since 2003, by organizing a themed exhibition that contributes to this major event promoting architecture all over the city of San Francisco.

Galleries and Exhibitions

Experience emerging artists at one of our galleries across San Francisco. Featuring the work of students, alumni, and faculty from Academy of Art University. Each gallery is designed to promote the work of our community and promote the arts in the Bay Area. The School of Architecture has two annual exhibits, where students have the opportunity to show their work to the public, as well as a selected audience of architects from all over the world.



Student work at the Atelier

“Architecture school has not only given me a career, it has changed the way I approach every single situation in my life.”

- Ricardo Moreno,
Architectural Designer
Mark Cavagnero Associates Architects



Our Alumni

With over 25,000 Academy of Art University alumni across the world and all AAU departments, we strive to keep our artist communities engaged and supported in their professional lives. The School of Architecture mentors students to step into the profession. Our successful alumni take the leap into rewarding careers and stay connected to the School of Architecture community.

RICARDO MORENO
Architectural Designer at
Mark Cavagnero Associates
Architects

As a child, Ricardo Moreno spent a lot of time sketching and thinking about the way things work.

“I realized that architecture was what really balanced everything out, very systematic and very engineer-oriented, but also very artistic.” After doing some research, he chose the Master of Architecture (M. Arch) program at Academy of Art University, which offered him an intensive curriculum as well as surroundings that inspired him.

Less than a year after graduating, Ricardo joined Mark Cavagnero Associates Architects, a high-profile group of architects currently working on the Moscone Expansion Project, designed to improve San Francisco’s downtown convention center. The firm

specializes in cultural architecture and has been heralded for its innovative work on the SFJAZZ Center, the Terrace at California Academy of Sciences and several arts and recreation centers.

The cultural aspect of architecture – as well as a building’s effects on the people who inhabit it – is foremost on Ricardo’s mind. “Architecture is misinterpreted to be about how pretty or how ugly a building is,” he said. “I think architecture is more about how people interact with each other, how they operate within certain parameters that you as an architect are envisioning.”

He continues to stay in touch with some of the faculty at the Academy, which he said, “challenged me in all the good ways.” “The scale of the school is really good. It’s still small and you have a lot of one-on-one experience with your professors. The faculty is very devoted to passing along information and



Ricardo Moreno M.Arch Alumnus

knowledge about architecture.”

Although he works long hours, Ricardo finds time to cycle around San Francisco taking photos for his portfolio of urban photography. He’s also a triathlete. When asked about his future goals, he replied, “I wouldn’t mind being at Mark Cavagnero for the next 10 years. They’re that good.”

Ricardo believes that modern architects need to evaluate the economical aspects, political aspects and cultural aspects of the projects they work on. “As an architect, I would like to impact the world by understanding it, and by understanding it making it more livable,” he said.

Featured Alumni

Samantha Buckley is one of the first graduates of our B.Arch program, her outstanding leadership skills were apparent early in her development. Now, apart from working as an architect she is also an architectural journalist, writing for Archdaily.com



SAMANTHA BUCKLEY
Designer/Technical at Gensler

During her studies Samantha was the Co-President of the AIAS AAU Chapter. "As president, I organized office tours, lectures, workshops, and networking events for the AAU AIAS members, and local chapters. Now I am the Site Director for the AIAS FORUM held in San Francisco in December 2015 hosting architecture students from all over the US. I am planning tours and helping with other site specific logistics."

Samantha's professional career is underway and gaining momentum. She is working at Gensler in San Francisco as a technical designer



Samantha Buckley and Giovanni Ribo B.Arch

after interning when she was a student with Michael Heacock Architects, an architecture and LEED sustainability consultancy.

Now, she plans to work full time while obtaining her license. She is particularly interested in restoration

and preservation projects within the Bay Area. Samantha is most interested in a work place that cultivates creative thinking, while applying sustainable strategies.



“My classmates and I have felt that our education has proven to be invaluable as we step into the profession. The program prepared us for a seamless transition between my education and career. I am so thankful for the support from my faculty in and outside the classroom.”

- Samantha Buckley,
B.Arch* Alumnus
Designer/Technical at Gensler

Online Education

Design studio critiques are central to the success of any architecture student. We keep this tradition by using web conferencing to interact with students, and bringing online guest reviewers and critics to participate in the design process.

Since 2002, Academy of Art University has helped thousands of online students from all over the world realize their professional and creative ambitions. Our revolutionary online courses provide the same rigorous education that we offer on campus with greater flexibility. Study on your own time, at your own pace. Take full or part-time classes. Let nothing stand in your way of pursuing your creative goals.



ASTIREH BARADARI
B.Arch Student School of Architecture

"I switched from being an onsite student, to online because my life circumstances changed. I can save time commuting, while receiving the same quality of instruction as the onsite classes. I have more discussion time with instructors, and have access to all the lectures, with the ability to review them throughout the semester. The online system is designed to be very user friendly, and my professors are very approachable."



BOB HERZOG
M.Arch Alumnus School of Architecture

"As a full time professional I found the on-line program at Academy Art University to be an excellent fit for me to pursue my Master of Architecture degree. At the time of my enrollment, there were only 2 universities in the United States offering a fully accredited completely on-line NAAB program. After researching the degree programs and staff at both universities, I selected AAU. I am very confident I made the right choice."



MAREN LONGHURST
M.Arch Alumna School of Architecture

"The Master of Architecture program at AAU is rich and diverse, with a global reach that fosters learning and collaboration with architecture students and faculty around the world on challenging design problems in the context of contemporary architecture. The online curriculum made it possible for me to earn my degree while supporting my family and working in the field of architecture."

“The School of Architecture online program allowed me to follow my dream while supporting my family - if I had to do it all over again, I wouldn’t change a thing.”

M.Arch Alumnus Ryan Boone
Valedictorian Class of 2017
AIA Henry Adams Medal recipient 2017



“I am so grateful there was the online program, this made the impossible, possible. I got a great education which is a view shared by my husband who runs a 48 person architecture firm.”

- Judy Roessner
Graduate School of Architecture Alumna
Sixthriver Architects / www.sixthriver.com

ONLINE INCLUDES

- ONE-ON-ONE SESSIONS WITH YOUR DIRECTOR
- ON-DEMAND DEMONSTRATION VIDEOS
- DIRECTOR Q&A
- TOWN HALL MEETINGS
- VIP GUEST SPEAKERS
- LIVE STREAMED EVENTS & PRESENTATIONS
- CAREER ADVICE & WORKSHOPS
- DIGITAL PORTFOLIO SHOWCASE

How The Courses Work

CREATE YOUR OWN CLASS SCHEDULE

When you take online courses at the Academy, you are free to manage your own time; there are no set class schedules that require you to be online at specific times of the day. Course content is divided evenly across 15 modules spread out during a semester. Each module’s coursework—instructional videos, audio-enhanced slideshows, digital documentation, interviews, and more— is made available at the start of each module period.

SUBMIT YOUR WORK & GET FEEDBACK

We have developed our own custom Learning Management System (LMS) to specifically teach art and design. The LMS is a centralized web tool that lets students and faculty easily interact and exchange digital assets. The LMS whiteboard feature allows instructors to mark up your work and provide detailed feedback, even audio commentary. The LMS also serves as your central hub for class news and updates, grade information, ESL support, scheduling one-on-one tutoring sessions, and a host of other features tailored to make your online education as rich as possible.

ENGAGE YOUR PEERS

You may work and study independently, but that does not mean you cannot call on the support of your online classmates. Each course offers a class discussion area where students and instructors can freely exchange thoughts, post work, and provide or receive creative feedback. The discussion area’s sole purpose is to give you and your peers the opportunity to support one another’s development as artists.

To find out more contact an admissions representative or go online: www.academyart.edu/online-education

Career Paths

As one of the top art schools in the country, Academy of Art University Architecture graduates have a range of opportunities to choose from as they take the next step into a multi-faceted design profession.

SELF EMPLOYED ARCHITECT (DESIGN FIRM PRINCIPAL)

operating as a sole practitioner, firm principals run small to mid-sized offices sometimes in partnership with other principals. Firm principals are responsible for signing and stamping construction documentation sets, and must be licensed in the state in which a project is being built.

PROJECT ARCHITECT

leading a team in a medium to large architectural design firm, tasked with the development of a complex architectural design, project architects work with other members of the architectural staff in a firm to coordinate and lead design decisions.

PROJECT DESIGNER

collaborating on large or complex architectural projects, project designers are members of a design team.

DESIGN CONSULTANT

applying a broad range of design skills that may be used in a variety of diverse design activities. Graduates from an architectural school are qualified outside of architectural practice, to consult across disciplines; from building envelope design, historical preservation, industrial design, furniture design, color, branding, business and product consulting, among many other possibilities.

SUSTAINABLE DESIGN CONSULTANT

specializing in sustainability-driven design projects sustainability consultants may be architects or other design professionals.

CITY AND URBAN PLANNER

master planning environmental design decisions at the scale of a neighborhood, district, city, or region, architects can be part of an urban or design team improving urban environments.

CONSTRUCTION MANAGER

managing and coordinating the design delivery of an architectural building project, from conception to final closeout. Architects can contribute their specific design knowledge within diverse construction teams as construction managers.

A SMALL SELECTION OF FIRMS WHERE SOME OF OUR ALUMNI WORK:



Licensing

Our NAAB accredited B.Arch (162 units) and M.Arch (63 and 87 units) degrees pave the path to licensure in the US. Obtaining a license as an architect includes meeting multiple requirements that are outlined below.

ARCHITECT LICENSURE REQUIREMENTS

The California Architects Board (the Board) oversees consumer protection and the regulation of licensed architects in the state of California. According to the Board, the following requirements must be met for licensure in California:

- Provide verification of five years of education equivalents and three years of architectural training (work) experience for a total of eight years of experience as evaluated by the Board;
- This includes a minimum of one year of work experience must be under the direct supervision of an architect licensed in a US jurisdiction or two years of experience under the direct supervision of an architect registered in a Canadian province;
- Successful completion of the Architect Registration Examination (ARE)
- Completion of the Architectural Experience Program (AXP)
- Successful completion of the California Supplemental Examination (CSE)

Candidates may meet these requirements in multiple ways.

For more information about becoming a licensed architect in the state of California, please visit the Board's website at:

<http://www.cab.ca.gov/>.

Enrollment of Students Not Eligible for Licensure (Graduate and Undergraduate)

Academy of Art University takes steps to determine whether prospective students may not be eligible to become licensed professionals prior to enrollment in programs that may lead to licensure. When a student is found to be ineligible for licensure based on California law, he/she must sign an affidavit as part of the enrollment process to confirm understanding of his/her ineligibility and to state objectives other than licensure. A copy of the signed affidavit will be provided to the student, and the original will be maintained in the student's file

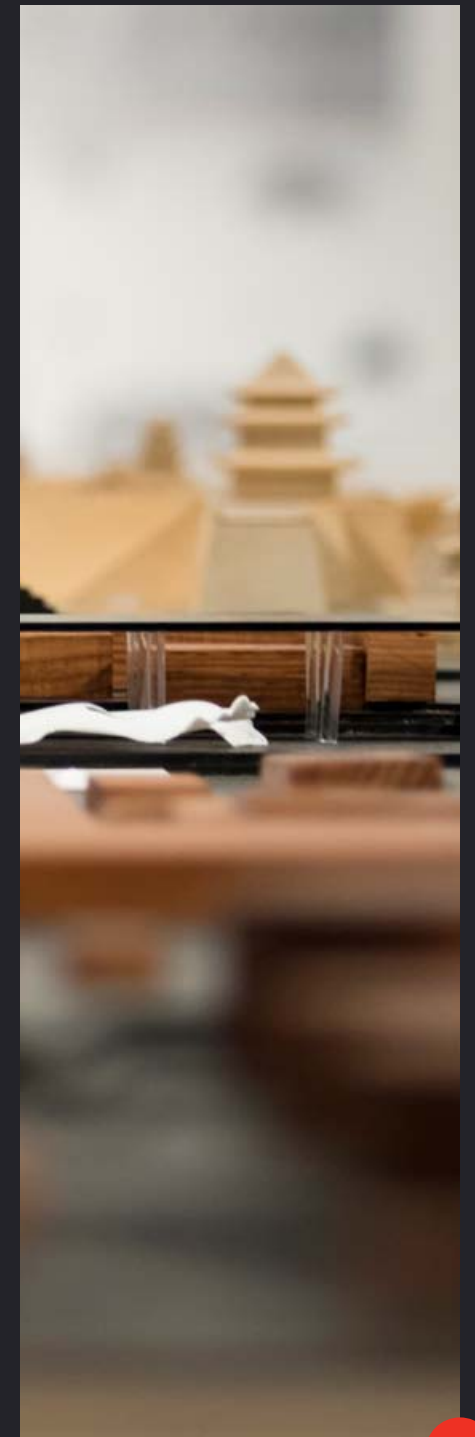

Academy Life

Discover life at the Academy. A substantial part of a students' growth and inspiration occurs outside the classroom or studio. At Academy of Art University, we understand this.

EVENTS

Campus Life is designed to inspire, educate, and promote fun. Our events are created in coordination with student-run groups and organizations. Make the most of your university experience: grow, learn, laugh, and run with us.

URBAN NIGHTS RADIO

Listen live online to our athletics teams, hear unique talk shows, and dance to your favorite tunes on UrbanKnightsRadio.com or iHeartRadio.

CULTURAL CLUBS

Everyone needs a break from the studio. With dozens of clubs and organizations, find a new creative outlet and build lifelong relationships.

ACADEMIC CLUBS

Join a community of Academy of Art University students with similar interests to discuss ideas, promote your work, form collaborations, and share information.

FITNESS & RECREATION

Get active and stay healthy with our free Campus Recreation classes and workshops, or use the gym, pool, basketball courts, and/or skateboard ramp.

VIRTUAL BOOKSTORE

All required textbooks are available at our virtual bookstore. As an Academy of Art University student, you can buy or sell textbooks here.

HOUSING

Housing is guaranteed for all new, full-time onsite students. We have 17 different housing options to choose from located in the heart of San Francisco near all of our academic buildings.

DINING

Stay healthy with delicious and filling meals in one of our dining halls with flexible meal plans and Knight Kash. The Knight Kash program enables your student ID for dining on campus and at select off-campus vendors, giving you the ultimate flexibility, variety, and value you deserve.

ATHLETICS

We believe in nurturing the whole artist by developing athletic ability along with artistic talent. We are proud to be the only higher arts education institution in the country to have an NCAA athletics program. Recreational intramural sports are also available. Learn more at artuathletics.com.

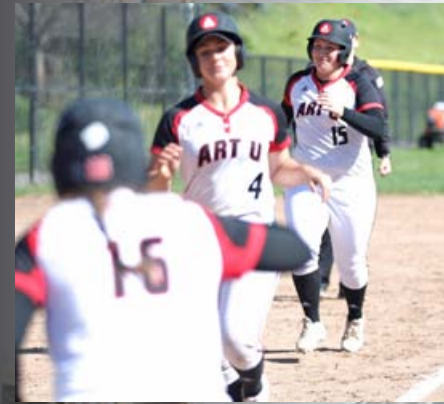

Visit Us

Experience our urban campus in the heart of San Francisco with a guided tour of galleries, exhibits, housing, and up-to-date facilities. Follow us on social media for up to the minute event information and to see our student work.

Call us at **415-618-8576**
or email us at
campustours@academyart.edu

and we will customize a tour
that's right for you.

Visit our Websites:
www.academyart.edu
www.academyart.edu/academics/architecture

and our Blogs:
www.architectureschooldaily.com
www.auschoolofarchitecture.com

Follow us:



facebook.com/aauarh



plus.google.com/+academyofartuniversity



youtube.com/user/academyofartu



twitter.com/academy_of_art



pinterest.com/academyofartuni



instagram.com/auschoolofarchitecture/



Academyofartu.tumblr.com



weheartit.com/academyofartu

Apply Today

Since 1929, we have helped thousands of art students from all over the world realize their professional and creative ambitions. Discover your creative potential, online and on campus in San Francisco.

WHEN TO APPLY

You can apply up to two years before you plan to enroll at Academy of Art University. Apply year-round to enroll for fall, spring and summer semesters. The Academy accepts applications through the first week of each semester.

PORTFOLIO

A portfolio is required for applications to the School of Architecture. The Graduate School of Architecture at the Academy of Art University is unique in that there are many advanced standing options for applicants with a background in architecture or a related field. The advanced standing is determined on an individual basis through a portfolio review and transcript evaluation. Apply today to find out about these options.

HOW TO APPLY

ONLINE AT:

academyart.edu

BY PHONE:

US applicants dial:

1.800.544.2787

International applicants dial:

+1.415.274.2208

IN PERSON (Monday-Saturday)

79 New Montgomery St.

San Francisco, CA 94501

INTERNATIONAL STUDENTS

EMAIL CONTACT:

intladmissions@academyart.edu

IN ORDER TO COMPLETE YOUR APPLICATION AND ADMISSION SOME FEES WILL APPLY:

- Please contact us to learn about application and admission fees for international and domestic students.
- Fees can be paid by MasterCard, Visa, Discover, or check/money order (by mail)

TRANSFER STUDENTS

- COMPLETE THE APPLICATION
- SUBMIT OFFICIAL ELECTRONIC TRANSCRIPTS TO:

transcripts@academyart.edu

OR MAIL OFFICIAL TRANSCRIPTS IN A SEALED ENVELOPE TO:

Academy of Art University

Attn: Admissions Office

79 New Montgomery St.

San Francisco, CA 94501

To jumpstart your transfer process, you may submit unofficial transcripts from a domestic college or university to transferoffice@academyart.edu. This will allow you to receive an evaluation in advance on previously completed coursework. Include your: first name, last name, phone number where you can be reached, and your area of interest at Academy of Art University..

Visit academyart.edu to learn more about total costs, median student loan debt, potential occupations and other information.

Academy of Art University admits students of any race, color, age, religion, and national or ethnic origin to all rights, privileges, programs, and activities generally accorded or made available to students at the school. The Academy does not discriminate on the basis of race, color, age, sex, religion, physical handicap, sexual orientation, or national or ethnic origin in administration of its educational policies, scholarship and loan programs, and other school-administered programs.

Image Licenses: * = [CC BY-SA 4.0] <https://creativecommons.org/licenses/by-sa/4.0/deed.en> | All other images:
** = [CC BY-SA 3.0] <https://creativecommons.org/licenses/by-sa/3.0/deed.en> | Academy of Art University

